

Mitsubishi Programmable Controller

MELSEC iQ-R
series

MELSEC iQ-R

Simple Motion Module Function Block Reference

CONTENTS

CHAPTER 1	List of FBs	3
<hr/>		
CHAPTER 2	Simple Motion Module FB	4
<hr/>		
2.1	M+RD77_SetPositioningData	4
2.2	M+RD77_StartPositioning	11
2.3	M+RD77_JOG	14
2.4	M+RD77_MPG	17
2.5	M+RD77_ChangeSpeed	20
2.6	M+RD77_ChangeAccDecTime	23
2.7	M+RD77_ChangePosition	26
2.8	M+RD77_Restart	29
2.9	M+RD77_OperateError	32
2.10	M+RD77_InitializeParameter	35
2.11	M+RD77_WriteFlash	37
2.12	M+RD77_ChangeServoParameter	39
2.13	M+RD77_ChangeTorqueControlMode	42
2.14	M+RD77_ChangeSpeedControlMode	45
2.15	M+RD77_ChangePositionControlMode	48
2.16	M+RD77_ChangeContinuousTorqueMode	51
2.17	M+RD77_Sync	55
2.18	M+RD77_ChangeSyncEncoderPosition	58
2.19	M+RD77_DisableSyncEncoder	61
2.20	M+RD77_EnableSyncEncoder	64
2.21	M+RD77_ResetSyncEncoderError	67
2.22	M+RD77_ConnectSyncEncoder	71
2.23	M+RD77_MoveCamReferencePosition	74
2.24	M+RD77_ChangeCamPositionPerCycle	77
2.25	M+RD77_ChangeMainShaftGearPositionPerCycle	80
2.26	M+RD77_ChangeAuxiliaryShaftGearPositionPerCycle	83
2.27	M+RD77_MoveCamPositionPerCycle	86
2.28	M+RD77_MakeRotaryCutterCam	89
2.29	M+RD77_CalcCamCommandPosition	91
2.30	M+RD77_CalcCamPositionPerCycle	93
<hr/>		
	INSTRUCTION INDEX	95
<hr/>		
	REVISIONS	97

1 List of FBs

This FB list is for using the MELSEC iQ-R series simple motion module.

Name	Description
M+RD77_SetPositioningData	Sets positioning data (Da.1 to Da.10, Da.20 to Da.22, Da.27 to Da.29).
M+RD77_StartPositioning	Starts the positioning operation.
M+RD77_JOG	Performs the JOG operation or inching operation.
M+RD77_MPG	Performs the manual pulse generator operation.
M+RD77_ChangeSpeed	Changes the speed.
M+RD77_ChangeAccDecTime	Changes the acceleration/deceleration time at a speed change.
M+RD77_ChangePosition	Changes the target position.
M+RD77_Restart	Restarts the axis being stopped.
M+RD77_OperateError	Monitors errors and warnings, and resets errors.
M+RD77_InitializeParameter	Initializes the parameter.
M+RD77_WriteFlash	Writes the parameter, positioning data, and block start data in the buffer memory to the flash ROM.
M+RD77_ChangeServoParameter	Changes the servo parameter after the amplifier is activated.
M+RD77_ChangeTorqueControlMode	Sets torque limit values in the forward direction and reverse direction individually.
M+RD77_ChangeSpeedControlMode	Activates the speed control mode.
M+RD77_ChangePositionControlMode	Activates the position control mode.
M+RD77_ChangeContinuousTorqueMode	Activates the continuous operation to torque control mode.
M+RD77_Sync	Starts and ends the synchronous control.
M+RD77_ChangeSyncEncoderPosition	Changes the synchronous encoder axis current value and synchronous encoder axis current value per cycle.
M+RD77_DisableSyncEncoder	Disables inputs from the synchronous encoder axis.
M+RD77_EnableSyncEncoder	Enables inputs from the synchronous encoder axis.
M+RD77_ResetSyncEncoderError	Reads error information from the synchronous encoder axis, and resets the error.
M+RD77_ConnectSyncEncoder	Connects a synchronous encoder via CPU.
M+RD77_MoveCamReferencePosition	Adds the movement amount set in the synchronous control change value to the cam reference position to move the cam reference position.
M+RD77_ChangeCamPositionPerCycle	Changes the cam axis current value per cycle to a synchronous control change value.
M+RD77_ChangeMainShaftGearPositionPerCycle	Changes the current value per cycle after main shaft gear to a synchronous control change value.
M+RD77_ChangeAuxiliaryShaftGearPositionPerCycle	Changes the current value per cycle after auxiliary shaft gear to a synchronous control change value.
M+RD77_MoveCamPositionPerCycle	Adds the movement amount set in the synchronous control change value to a cam axis current value per cycle to move the cam axis current value per cycle.
M+RD77_MakeRotaryCutterCam	Automatically generates the cam for a rotary cutter.
M+RD77_CalcCamCommandPosition	Calculates a cam axis feed current value, and outputs the calculation result.
M+RD77_CalcCamPositionPerCycle	Calculates a cam axis current value per cycle, and outputs the calculation result.

2 Simple Motion Module FB

2.1 M+RD77_SetPositioningData

Name

M+RD77_SetPositioningData

Function overview

Item	Description	
Function overview	Sets positioning data (Da.1 to Da.10, Da.20 to Da.22, Da.27 to Da.29).	
Symbol	<p>The diagram shows a central block labeled 'M+RD77 SetPositioningData'. On the left side, there are four input lines: 'Execution command' connected to 'B : i_bEN', 'Module label' connected to 'DUT : i_stModule', 'Target axis' connected to 'UW : i_uAxis', and 'Positioning data No.' connected to 'UW : i_uDataNo'. On the right side, there are four output lines: 'o_bENO : B' connected to 'Execution status', 'o_bOK : B' connected to 'Completed without error', 'o_bErr : B' connected to 'Error flag', and 'o_uErrId : UW' connected to 'Error code'.</p>	
Applicable hardware and software	Applicable module	RD77MS16, RD77MS8, RD77MS4, RD77MS2
	Applicable CPU	MELSEC iQ-R series
	Applicable engineering software	GX Works3
Programming language	Ladder	
Number of steps (maximum)	209 steps	
Function description	<ul style="list-style-type: none"> • By turning ON i_bEN (Execution command), the set positioning data is written to the buffer memory. • When the setting value of the target axis is out of the range, o_bErr (Error flag) turns ON, the FB processing is interrupted, and the error code 100 (Hexadecimal) is stored in o_uErrId (Error code). • When the setting value of the positioning data No. is out of the range, o_bErr (Error flag) turns ON, the FB processing is interrupted, and the error code 101 (Hexadecimal) is stored in o_uErrId (Error code). 	
Compiling method	Macro type	
FB operation type	Pulsed execution (single scan execution type)	

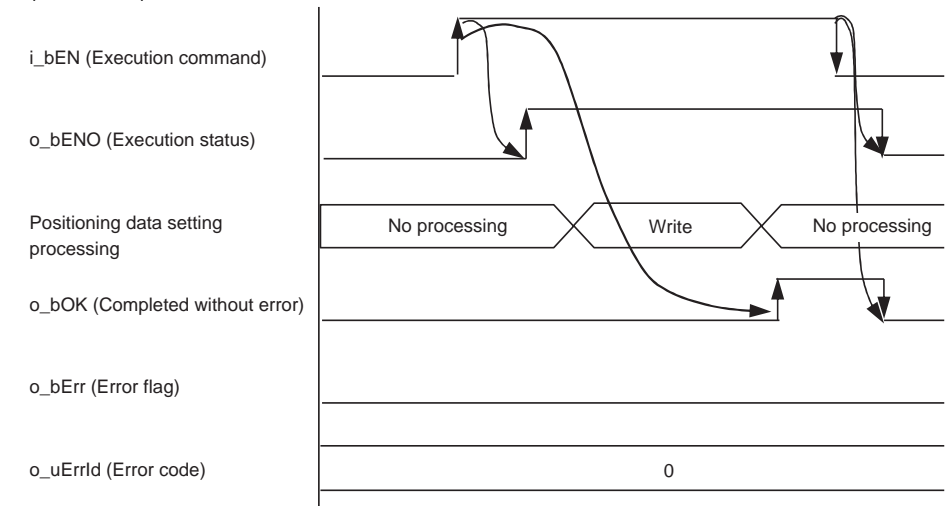
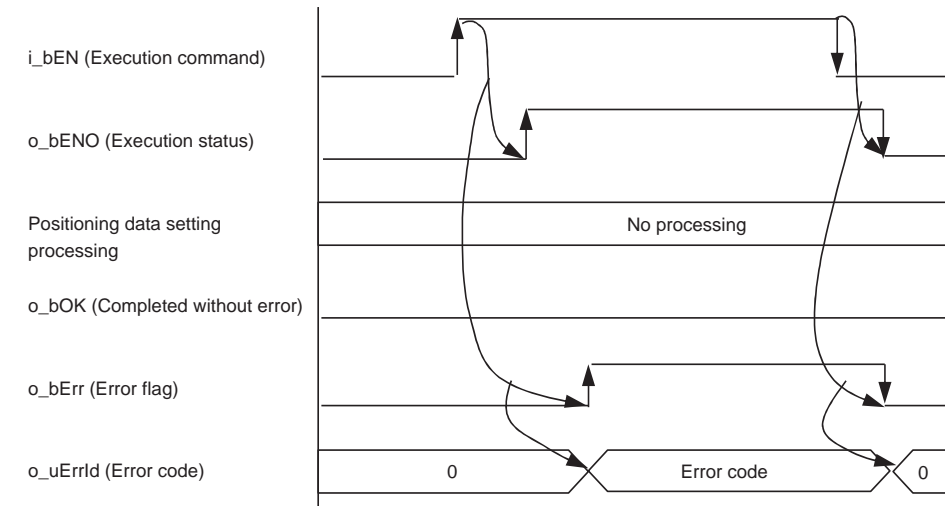
Item	Description
Timing chart	<p>When operation completes without an error</p>  <p>When an error occurs</p> 
Restrictions and precautions	<ul style="list-style-type: none"> • The FB does not include error recovery processing. Program the error recovery processing separately in accordance with the required system operation. • The FB cannot be used in an interrupt program. • Ensure that i_bEN (Execution command) is capable of being turned OFF by the program. Do not use this FB in programs that are only executed once such as a subroutine and FOR-NEXT loop because i_bEN (Execution command) cannot be turned OFF. • When this FB is used twice or more, precaution must be taken to avoid repetition of the target axis. • Every input must be provided with a value for proper FB operation.

Error codes

Error code	Description	Action
100 (Hexadecimal)	The setting value of i_uAxis (Target axis) is out of the range. The target axis is not within the range of 1 to 16.	Please try again after confirming the setting.
101 (Hexadecimal)	The setting value of i_uDataNo (Positioning data No.) is out of the range. The positioning data No. is not within the range of 1 to 100.	Please try again after confirming the setting.

Labels

■Input labels

Name	Variable name	Data type	Setting range	Description
Execution command	i_bEN	Bit	ON, OFF	ON: The FB is activated. OFF: The FB is not activated.
Module label	i_stModule	Structure	The setting range differs depending on the module label.	Specify the module label of the MELSEC iQ-R simple motion module.
Target axis	i_uAxis	Word [unsigned]	1 to 16	Specify the axis number. The setting range differs depending on the module used.
Positioning data No.	i_uDataNo	Word [unsigned]	1 to 100	Specify the positioning data No.

■Output labels

Name	Variable name	Data type	Default value	Description
Execution status	o_bENO	Bit	OFF	ON: The execution command is ON. OFF: The execution command is OFF.
Completed without error	o_bOK	Bit	OFF	When ON, it indicates that setting the positioning data has been completed.
Error flag	o_bErr	Bit	OFF	When ON, it indicates that an error has occurred in the FB.
Error code	o_uErrId	Word [unsigned]	0	The error code generated in the FB is stored.

■ Disclosed labels

Name	Variable name	Data type	Setting range	Description
Da.1: Operation pattern	pb_uOpePattern	Word [unsigned]	0: Positioning complete 1: Continuous positioning control 3: Continuous path control	Specify whether the positioning is completed with the data being executed, or continues with the following data. When 4 or higher, which is out of the setting range, is specified, bit 0 and 1 are enabled. For example, when 4 is set, 0 is applied.
Da.2: Control system	pb_uCtrlSys	Word [unsigned]	01H: ABS1 1-axis linear control (ABS) 02H: INC1 1-axis linear control (INC) 03H: FEED1 1-axis fixed-feed control 04H: VF1 1-axis speed control (Forward) 05H: VR1 1-axis speed control (Reverse) 06H: VPF Speed-position switching control (Forward) 07H: VPR Speed-position switching control (Reverse) 08H: PVF Position-speed switching control (Forward) 09H: PVR Position-speed switching control (Reverse) 0AH: ABS2 2-axis linear interpolation control (ABS) 0BH: INC2 2-axis linear interpolation control (INC) 0CH: FEED2 Fixed-feed control by 2-axis linear interpolation 0DH: ABS [^] Circular interpolation control with sub point designation (ABS) 0EH: INC [^] Circular interpolation control with sub point designation (INC) 0FH: ABS. Circular interpolation control with center point designation (ABS, CW) 10H: ABS. Circular interpolation control with center point designation (ABS, CCW) 11H: INC. Circular interpolation control with center point designation (INC, CW) 12H: INC. Circular interpolation control with center point designation (INC, CCW) 13H: VF2 2-axis speed control (Forward) 14H: VR2 2-axis speed control (Reverse) 15H: ABS3 3-axis linear interpolation control (ABS) 16H: INC3 3-axis linear interpolation control (INC) 17H: FEED3 Fixed-feed control by 3-axis linear interpolation 18H: VF3 3-axis speed control (Forward) 19H: VR3 3-axis speed control (Reverse) 1AH: ABS4 4-axis linear interpolation control (ABS) 1BH: INC4 4-axis linear interpolation control (INC) 1CH: FEED4 Fixed-feed control by 4-axis linear interpolation 1DH: VF4 4-axis speed control (Forward) 1EH: VR4 4-axis speed control (Reverse) 80H: NOP NOP instruction 81H: POS Current value changing 82H: JUMP JUMP instruction 83H: LOOP Top of LOOP-LEND loop 84H: LEND End of LOOP-LEND loop	Sets the control system for positioning control.
Da.3: Acceleration time No.	pb_uAccTimeNo	Word [unsigned]	0: Acceleration time 0 1: Acceleration time 1 2: Acceleration time 2 3: Acceleration time 3	Set any of the acceleration time 0 to 3 as the acceleration time for positioning. When 4 or higher, which is out of the setting range, is specified, bit 0 and 1 are enabled. For example, when 4 is set, 0 is applied.

Name	Variable name	Data type	Setting range	Description
Da.4: Deceleration time No.	pb_uDecTimeNo	Word [unsigned]	0: Deceleration time 0 1: Deceleration time 1 2: Deceleration time 2 3: Deceleration time 3	Set any of the deceleration time 0 to 3 as the deceleration time for positioning. When 4 or higher, which is out of the setting range, is specified, bit 0 and 1 are enabled. For example, when 4 is set, 0 is applied.
Da.10: M code	pb_uMcode	Word [unsigned]	Da.2: Control system = 82H: JUMP instruction • 0 to 10 Da.2: Control system = 83H: LOOP • 1 to 65535 Da.2: Control system = Other than the above • 0 to 65535 (0 to 32767: Set by decimal number. 32768 to 65535: Convert the number to hexadecimal number and set.)	Set the condition data No., number of repetitions, or M code for the control system.
Da.9: Dwell time	pb_uDwellTime	Word [unsigned]	Da.2: Control system = 82H: JUMP instruction • 1 to 600 Da.2: Control system = 82H: Other than JUMP instruction • 0 to 65535 (0 to 32767: Set by decimal number. 32768 to 65535: Convert the number to hexadecimal number and set.)	Set the positioning data No. or dwell time for the control system.
Da.27: M code ON signal output timing	pb_uMcodeOnTiming	Word [unsigned]	0: Setting value of Pr.18 M code ON signal output timing 1: WITH mode 2: AFTER mode	Set the timing to output the M code ON signal. When 4 or higher is specified, bit 0 and 1 are enabled. For example, when 4 is set, 0 is applied.
Da.28: ABS direction in degrees	pb_uABS	Word [unsigned]	0: Setting value of Cd.40 ABS direction in degrees 1: ABS circular right 2: ABS circular left 3: Takes a shortcut. (Specified direction ignored.)	Set the movement direction of ABS when the unit is degree under position control. When 4 or higher, which is out of the setting range, is specified, bit 0 and 1 are enabled. For example, when 4 is set, 0 is applied.
Da.29: Interpolation speed designation method	pb_uInterpolateSpd	Word [unsigned]	0: Setting value of Pr.20 Interpolation speed designation method. 1: Composite speed 2: Reference axis speed	Set whether to specify the composite speed or reference axis speed when performing linear interpolation or circular interpolation. When 8 or higher is specified, bit 0, 1, and 2 are enabled. For example, when 8 is set, 0 is applied.
Da.8: Command speed	pb_udCmdSpd	Double word [unsigned]	Pr.1: Unit setting = 0, 1, 2 • 1 to 2,000,000,000 Pr.1: Unit setting = 3 • 1 to 5,000,000 FFFFFFFFH: Current speed (Speed set for the previous positioning data No.)	Set the command speed for positioning. The speed set for the previous positioning data No. is used for positioning control.

Name	Variable name	Data type	Setting range	Description
Da.6: Positioning address	pb_dPositAdr	Double word [signed]	Pr.1: Unit setting = 0, 1, 3 • Da.2: Control system = 06H to 09H: 0 to 2,147,483,647 Pr.1: Unit setting = 0, 1, 3 • Da.2: Control system = Other than 06H to 09H: -2,147,483,648 to 2,147,483,647 Pr.1: Unit setting = 2 • Da.2: Control system = 01H, 0AH, 15H, 1AH, 81H, 20H, 22H, 23H: 0 to 35,999,999 Pr.1: Unit setting = 2 • Da.2: Control system = 02H, 0BH, 16H, 1BH, 03H, 0CH, 17H, 1CH, 20H, 22H, 23H: -2,147,483,648 to 2,147,483,647 Pr.1: Unit setting = 2 • Da.2: Control system = 06H, 07H: 0 to 2,147,483,647 (INC mode), 0 to 35,999,999 (ABS mode) Pr.1: Unit setting = 2 • Da.2: Control system = 08H, 09H: 0 to 2,147,483,647	Specify the target position or movement amount for positioning control. The setting value differs depending on the control system.
Da.7: Arc address	pb_dArcAdr	Double word [signed]	Pr.1: Unit setting = 0, 1, 3 • -2,147,483,648 to 2,147,483,647 Pr.1: Unit setting = 2 • Unused (Set 0.)	Use this label only when performing circular interpolation control. For the control with sub point designation, set the sub point address. For the control with center point designation, set the center point address of the arc.
Da.20: Axis to be interpolated No. 1	pb_ulinterpolatedAxNo1	Word [unsigned]	0H: Axis 1 1H: Axis 2 2H: Axis 3 3H: Axis 4 4H: Axis 5 5H: Axis 6 6H: Axis 7 : : EH: Axis 15 FH: Axis 16	Set the interpolation-target axis 1 when performing interpolation operation. Values out of the setting range or the own axis cannot be set as the interpolation-target axis. Set 0 to disable the interpolation. When 100H or higher is set, lower 8 bits (bit 0 to 7) are enabled. For example, when 101H is set, 1H is applied.
Da.21: Axis to be interpolated No. 2	pb_ulinterpolatedAxNo2	Word [unsigned]	0H: Axis 1 1H: Axis 2 2H: Axis 3 3H: Axis 4 4H: Axis 5 5H: Axis 6 6H: Axis 7 : : EH: Axis 15 FH: Axis 16	Set the interpolation-target axis 2 when performing interpolation operation. Values out of the setting range or the own axis cannot be set as the interpolation-target axis. Set 0 to disable the interpolation or for 2-axis interpolation control. When 100H or higher is set, lower 8 bits (bit 0 to 7) are enabled. For example, when 101H is set, 1H is applied.

Name	Variable name	Data type	Setting range	Description
Da.22: Axis to be interpolated No. 3	pb_ulInterpolatedAxNo3	Word [unsigned]	0H: Axis 1 1H: Axis 2 2H: Axis 3 3H: Axis 4 4H: Axis 5 5H: Axis 6 6H: Axis 7 : : EH: Axis 15 FH: Axis 16	Set the interpolation-target axis 3 when performing interpolation operation. Values out of the setting range or the own axis cannot be set as the interpolation-target axis. Set 0 to disable the interpolation, for 2-axis interpolation control, or for 3-axis interpolation control. When 100H or higher is set, lower 8 bits (bit 0 to 7) are enabled. For example, when 101H is set, 1H is applied.

Version upgrade history

Version	Date	Description
00D	2014/06/30	First edition

2.2 M+RD77_StartPositioning

Name

M+RD77_StartPositioning

Function overview

Item	Description						
Function overview	Starts the positioning operation.						
Symbol							
Applicable hardware and software	<table border="1"> <tr> <td>Applicable module</td> <td>RD77MS16, RD77MS8, RD77MS4, RD77MS2</td> </tr> <tr> <td>Applicable CPU</td> <td>MELSEC iQ-R series</td> </tr> <tr> <td>Applicable engineering software</td> <td>GX Works3</td> </tr> </table>	Applicable module	RD77MS16, RD77MS8, RD77MS4, RD77MS2	Applicable CPU	MELSEC iQ-R series	Applicable engineering software	GX Works3
Applicable module	RD77MS16, RD77MS8, RD77MS4, RD77MS2						
Applicable CPU	MELSEC iQ-R series						
Applicable engineering software	GX Works3						
Programming language	Ladder						
Number of steps (maximum)	410 steps						
Function description	<ul style="list-style-type: none"> • By turning ON i_bEN (Execution command), the control corresponding to i_uStartNo (Cd.3: Positioning start No.) is started. • This FB is activated by turning ON the positioning start signal (Y10 to Y1F). • Only when the conditions are met, the positioning start signal (Y10 to Y1F) is turned ON by turning ON i_bEN (Execution command). The conditions are the following: RD77 READY (X0) is ON, positioning start signal (Y10 to Y1F) is OFF, start complete signal (Md.31) is OFF, and BUSY signal (X10 to X1F) is OFF. If any of the conditions is not met, the error code 200 (hexadecimal) is stored in o_uErrId (Error code). • When the start complete signal (Md.31) is turned ON or i_bEN (Execution command) is turned OFF, the positioning start signal (Y10 to Y1F) is turned OFF. • When the setting value of the target axis is out of the range, o_bErr (Error flag) turns ON, the FB processing is interrupted, and the error code 100 (Hexadecimal) is stored in o_uErrId (Error code). • When the setting value of the positioning start No. is out of the range, o_bErr (Error flag) turns ON, the FB processing is interrupted, and the error code 102 (Hexadecimal) is stored in o_uErrId (Error code). 						
Compiling method	Macro type						
FB operation type	Pulsed execution (multiple scan execution type)						

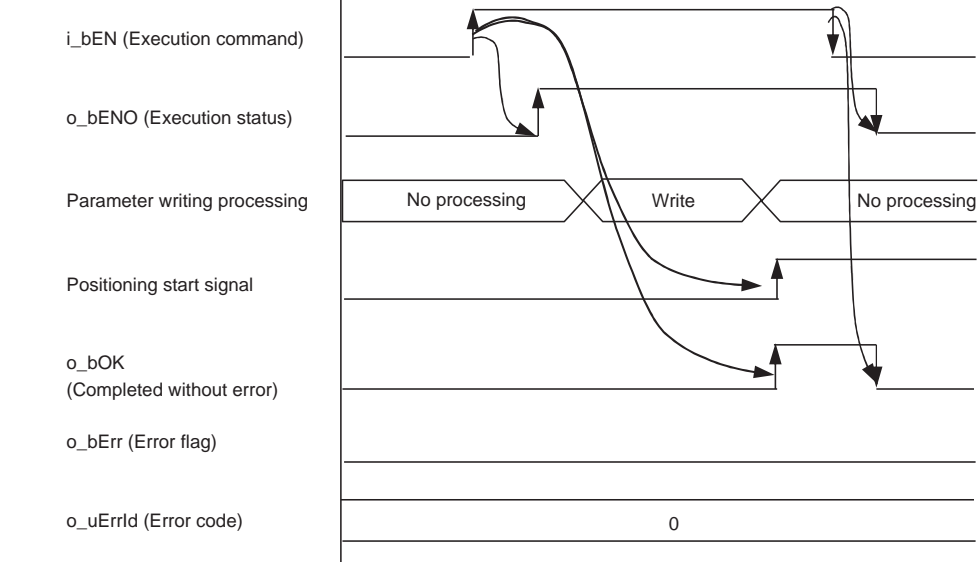
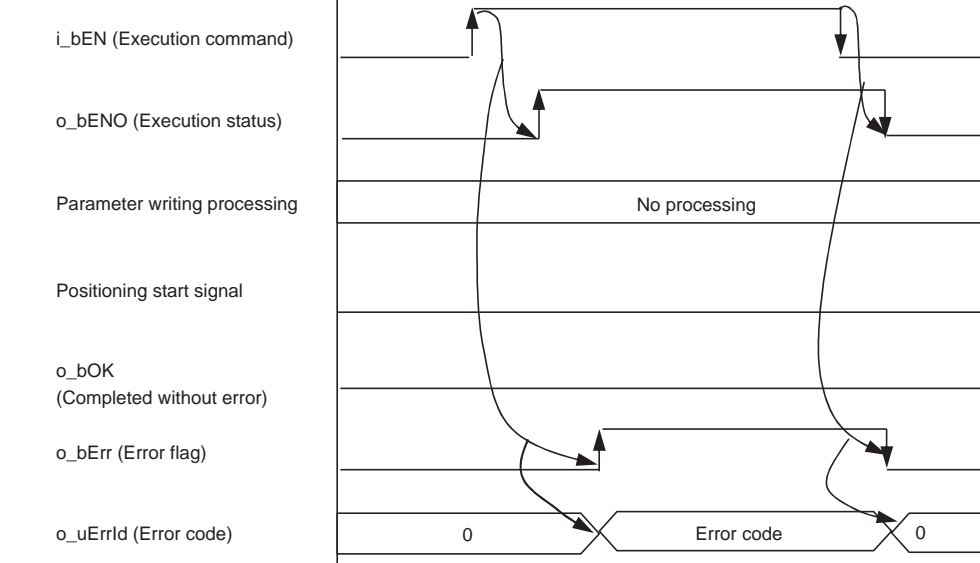
Item	Description
Timing chart	<p>When operation completes without an error</p>  <p>When an error occurs</p> 
Restrictions and precautions	<ul style="list-style-type: none"> • The FB does not include error recovery processing. Program the error recovery processing separately in accordance with the required system operation. • The FB cannot be used in an interrupt program. • Ensure that i_bEN (Execution command) is capable of being turned OFF by the program. Do not use this FB in programs that are only executed once such as a subroutine and FOR-NEXT loop because i_bEN (Execution command) cannot be turned OFF. • This FB turns ON and OFF the positioning start signal (Y10 to Y1F). Thus, do not turn ON or OFF the positioning start signal (Y10 to Y1F) by the other means while this FB is being executed. • When this FB is used twice or more or other FB that operates the Y signal same as the signal this FB does, create an interlock to prevent the FBs from being activated at the same time. • When this FB is used twice or more, precaution must be taken to avoid repetition of the target axis. • When this FB is used in two or more places, a duplicated coil warning may occur during compile operation due to the Y signal being operated by the module label. However, this is not a problem and the FB will operate without an error. • This FB does not set the data when started. Data required for controlling the start No. must be set on the parameter or buffer memory. • Every input must be provided with a value for proper FB operation.

Error codes

Error code	Description	Action
100 (Hexadecimal)	The setting value of i_uAxis (Target axis) is out of the range. The target axis is not within the range of 1 to 16.	Please try again after confirming the setting.
102 (Hexadecimal)	The setting value of i_uStartNo (Cd.3: Positioning start No.) is out of the range. The positioning start No. is not within the range of 1 to 600, 7000 to 7004, and 9001 to 9004.	Please try again after confirming the setting.
200 (Hexadecimal)	The condition for positioning start is not met. Any of the following conditions is not met. <ul style="list-style-type: none"> RD75 READY: On Positioning start signal: Off Start complete signal: Off BUSY signal: Off 	Execute the FB when all of the following conditions are met. <ul style="list-style-type: none"> RD75 READY: On Positioning start signal: Off Start complete signal: Off BUSY signal: Off

Labels

Input labels

Name	Variable name	Data type	Setting range	Description
Execution command	i_bEN	Bit	ON, OFF	ON: The FB is activated. OFF: The FB is not activated.
Module label	i_stModule	Structure	The setting range differs depending on the module label.	Specify the module label of the MELSEC iQ-R simple motion module.
Target axis	i_uAxis	Word [unsigned]	1 to 16	Specify the axis number. The setting range differs depending on the module used.
Cd.3: Positioning start No.	i_uStartNo	Word [unsigned]	1 to 600: Positioning data No. 7000 to 7004: Block start designation 9001: Machine home position return 9002: Fast-home position return 9003: Current value changing 9004: Simultaneous starting of multiple axes	Set the positioning start No. corresponding to the control to be started in Cd.3: Positioning start No.

Output labels

Name	Variable name	Data type	Default value	Description
Execution status	o_bENO	Bit	OFF	ON: The execution command is ON. OFF: The execution command is OFF.
Completed without error	o_bOK	Bit	OFF	When ON, it indicates that executing this FB has been completed. However, this label does not turn ON when a module error occurs at the start.
Error flag	o_bErr	Bit	OFF	When ON, it indicates that an error has occurred in the FB.
Error code	o_uErrId	Word [unsigned]	0	The error code generated in the FB is stored.

Version upgrade history

Version	Date	Description
00D	2014/06/30	First edition

2.3 M+RD77_JOG

Name

M+RD77_JOG

Function overview

Item	Description	
Function overview	Performs the JOG operation or inching operation.	
Symbol	<p>The diagram shows a rectangular block labeled 'M+RD77_JOG'. On the left side, there are six input lines: 'Execution command' (B : i_bEN), 'Module label' (DUT : i_stModule), 'Target axis' (UW : i_uAxis), 'Forward run JOG command' (B : i_bFJog), 'Reverse run JOG command' (B : i_bRJog), and 'Cd.17: JOG speed' (UD : i_udJogSpeed). On the right side, there are four output lines: 'o_bENO : B' (Execution status), 'o_bOK : B' (Completed without error), 'o_bErr : B' (Error flag), and 'o_uErrId : UW' (Error code). At the bottom left, there is an input line 'Cd.16: Inching movement amount' (UW : i_uInching).</p>	
Applicable hardware and software	Applicable module	RD77MS16, RD77MS8, RD77MS4, RD77MS2
	Applicable CPU	MELSEC iQ-R series
	Applicable engineering software	GX Works3
Programming language	Ladder	
Number of steps (maximum)	384 steps	
Function description	<ul style="list-style-type: none"> • By turning ON i_bFJog (Forward run JOG command) or i_bRJog (Reverse run JOG command) after i_bEN (Execution command) is turned ON, the JOG operation or inching operation is performed. • When i_bFJog (Forward run JOG command) and i_bRJog (Reverse run JOG command) are ON at the same time, the operation stops. • When i_bEN (Execution command) is turned OFF from ON during operation that has been started by i_bFJog (Forward run JOG command) or i_bRJog (Reverse run JOG command), the operation stops. • When i_bRJog (Reverse run JOG command) is turned ON during forward run JOG operation, the operation stops. However, when i_bRJog (Reverse run JOG command) is turned OFF from ON, the forward run JOG operation restarts. (This relation is also applied to the reverse run JOG operation and i_bFJog (Forward run JOG command).) • When the setting value of the target axis is out of the range, o_bErr (Error flag) turns ON, the FB processing is interrupted, and the error code 100 (Hexadecimal) is stored in o_uErrId (Error code). 	
Compiling method	Macro type	
FB operation type	Real-time execution	

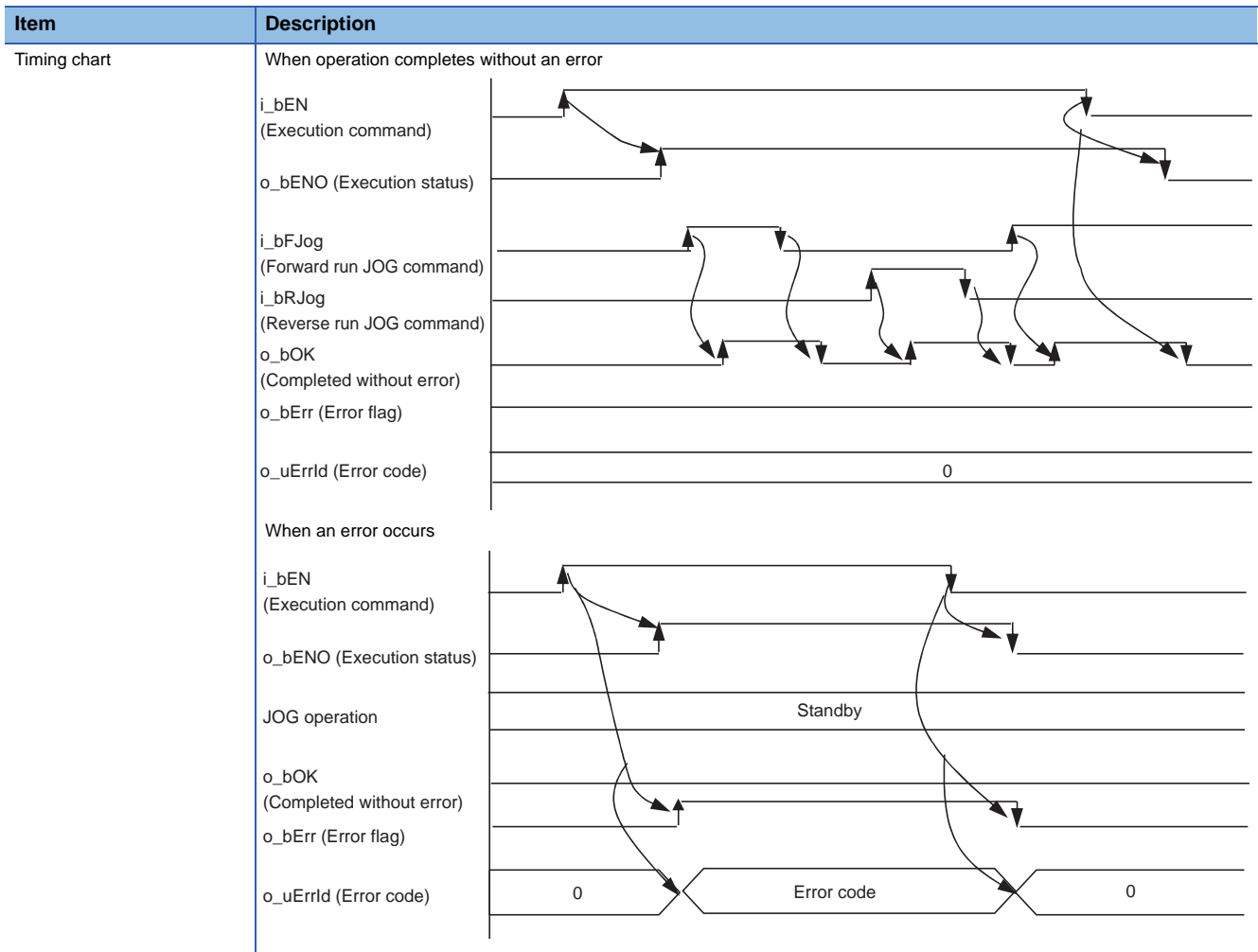

- Restrictions and precautions
- The FB does not include error recovery processing. Program the error recovery processing separately in accordance with the required system operation.
 - The FB cannot be used in an interrupt program.
 - Ensure that i_bEN (Execution command) is capable of being turned OFF by the program. Do not use this FB in programs that are only executed once such as a subroutine and FOR-NEXT loop because i_bEN (Execution command) cannot be turned OFF.
 - This FB turns ON and OFF the forward run JOG start signal (Cd.181) or reverse run JOG start signal (Cd.182). Thus, do not turn ON or OFF the forward run JOG start signal (Cd.181) or reverse run JOG start signal (Cd.182) by the other means while this FB is being executed.
 - When this FB is used twice or more or other FB that operates the Y signal same as the signal this FB does, create an interlock to prevent the FBs from being activated at the same time.
 - When this FB is used twice or more, precaution must be taken to avoid repetition of the target axis.
 - Setting a large value for the JOG speed from the beginning is dangerous. For the safety, set a small value first, and increase the value gradually while checking the operation to determine the value optimal for the control.
 - When values other than 0 are set in both i_uInching (Cd.16: Inching movement amount) and i_udJogSpeed (Cd.17: JOG speed), inching operation is performed.
 - When this FB is used in two or more places, a duplicated coil warning may occur during compile operation due to the Y signal being operated by the module label. However, this is not a problem and the FB will operate without an error.
 - Every input must be provided with a value for proper FB operation.

Error codes

Error code	Description	Action
100 (Hexadecimal)	The setting value of i_uAxis (Target axis) is out of the range. The target axis is not within the range of 1 to 16.	Please try again after confirming the setting. (Turn OFF the forward run JOG command or reverse run JOG command, turn ON i_bEN from OFF, and turn ON the forward run JOG command or reverse run JOG command again.)

Labels

■ Input labels

Name	Variable name	Data type	Setting range	Description
Execution command	i_bEN	Bit	ON, OFF	ON: The FB is activated. OFF: The FB is not activated.
Module label	i_stModule	Structure	The setting range differs depending on the module label.	Specify the module label of the MELSEC iQ-R simple motion module.
Target axis	i_uAxis	Word [unsigned]	1 to 16	Specify the axis number. The setting range differs depending on the module used.
Forward run JOG command	i_bfJog	Bit	ON, OFF	Turn ON this label when performing the forward run JOG operation or forward run inching operation.
Reverse run JOG command	i_brJog	Bit	ON, OFF	Turn ON this label when performing the reverse run JOG operation or reverse run inching operation.
Cd.17: JOG speed	i_udJogSpeed	Double word [unsigned]	Pr.1: Unit setting = mm • 0 to 2000000000 Pr.1: Unit setting = inch • 0 to 2000000000 Pr.1: Unit setting = degree • 0 to 2000000000 Pr.1: Unit setting = pulse • 0 to 1000000000	Specify the JOG speed. For inching operation, set 0.
Cd.16: Inching movement amount	i_ulnching	Word [unsigned]	0 to 65535 0: JOG operation (0 to 32767: Set by decimal number. 32768 to 65535: Convert the number to hexadecimal number and set.)	Specify the inching movement amount. For JOG operation, set 0.

■ Output labels

Name	Variable name	Data type	Default value	Description
Execution status	o_bENO	Bit	OFF	ON: The execution command is ON. OFF: The execution command is OFF.
Completed without error	o_bOK	Bit	OFF	ON: The JOG command is ON. OFF: The JOG command is OFF.
Error flag	o_bErr	Bit	OFF	When ON, it indicates that an error has occurred in the FB.
Error code	o_uErrId	Word [unsigned]	0	The generated error code is stored.

Version upgrade history

Version	Date	Description
00D	2014/06/30	First edition

2.4 M+RD77_MPG

Name

M+RD77_MPG

Function overview

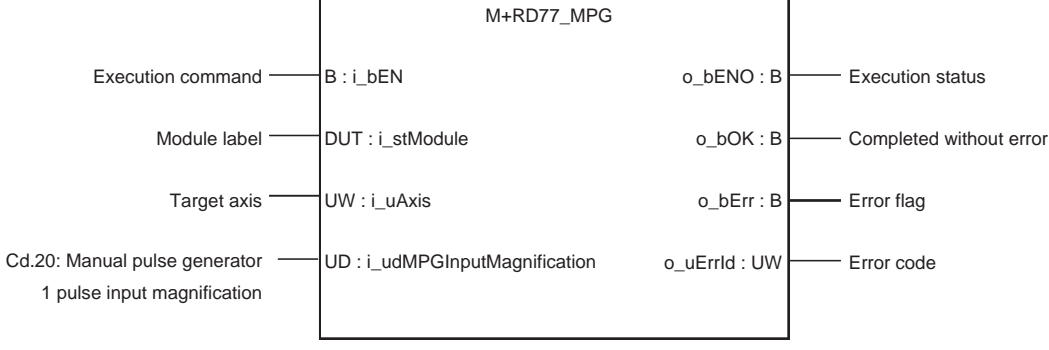
Item	Description	
Function overview	Performs the manual pulse generator operation.	
Symbol		
Applicable hardware and software	Applicable module	RD77MS16, RD77MS8, RD77MS4, RD77MS2
	Applicable CPU	MELSEC iQ-R series
	Applicable engineering software	GX Works3
Programming language	Ladder	
Number of steps (maximum)	336 steps	
Function description	<ul style="list-style-type: none"> • By turning ON or OFF i_bEN (Execution command), manual pulse generator operation is enabled or disabled. • This FB is constantly executed after i_bEN (Execution command) is turned ON. • The workpiece moves according to the pulses input from the manual pulse generator while o_bOK (Completed without error) is ON. • When the setting value of the target axis is out of the range, o_bErr (Error flag) turns ON, the FB processing is interrupted, and the error code 100 (Hexadecimal) is stored in o_uErrId (Error code). 	
Compiling method	Macro type	
FB operation type	Real-time execution	

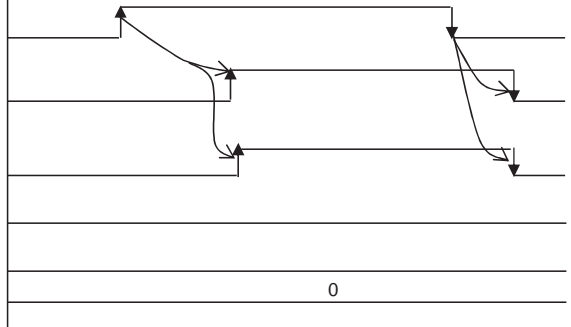
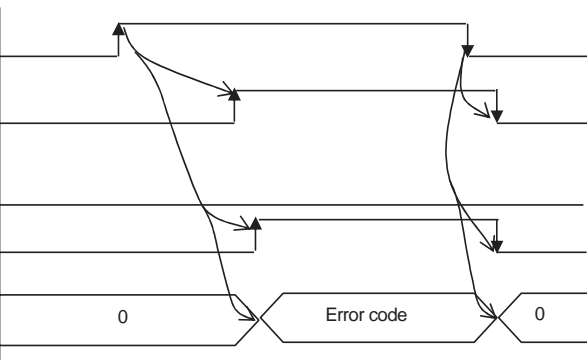
Item	Description
Timing chart	<p>When operation completes without an error</p>  <p>When an error occurs</p> 
Restrictions and precautions	<ul style="list-style-type: none"> • The FB does not include error recovery processing. Program the error recovery processing separately in accordance with the required system operation. • The FB cannot be used in an interrupt program. • Ensure that i_bEN (Execution command) is capable of being turned OFF by the program. Do not use this FB in programs that are only executed once such as a subroutine and FOR-NEXT loop because i_bEN (Execution command) cannot be turned OFF. • Do not change i_uAxis (Target axis) while i_bEN (Execution command) is ON. • When this FB is used twice or more, precaution must be taken to avoid repetition of the target axis. • Every input must be provided with a value for proper FB operation.

Error codes

Error code	Description	Action
100 (Hexadecimal)	The setting value of i_uAxis (Target axis) is out of the range. The target axis is not within the range of 1 to 16.	Please try again after confirming the setting.

Labels

Input labels

Name	Variable name	Data type	Setting range	Description
Execution command	i_bEN	Bit	ON, OFF	ON: The FB is activated. OFF: The FB is not activated.
Module label	i_stModule	Structure	The setting range differs depending on the module label.	Specify the module label of the MELSEC iQ-R simple motion module.
Target axis	i_uAxis	Word [unsigned]	1 to 16	Specify the axis number. The setting range differs depending on the module used.
Cd.20: Manual pulse generator 1 pulse input magnification	i_udMPGInputMagnification	Double word [unsigned]	1 to 10,000	Set the input magnification of the manual pulse generator 1 pulse. When the setting value is 0, the magnification is 1. When the setting value is 10,001 or higher, the magnification is 10,000.

■Output labels

Name	Variable name	Data type	Default value	Description
Execution status	o_bENO	Bit	OFF	ON: The execution command is ON. OFF: The execution command is OFF.
Completed without error	o_bOK	Bit	OFF	When ON, it indicates that the manual pulse generator operation has been enabled.
Error flag	o_bErr	Bit	OFF	When ON, it indicates that an error has occurred in the FB.
Error code	o_uErrId	Word [unsigned]	0	The error code generated in the FB is stored.

Version upgrade history

Version	Date	Description
00D	2014/06/30	First edition

2.5 M+RD77_ChangeSpeed

Name

M+RD77_ChangeSpeed

Function overview

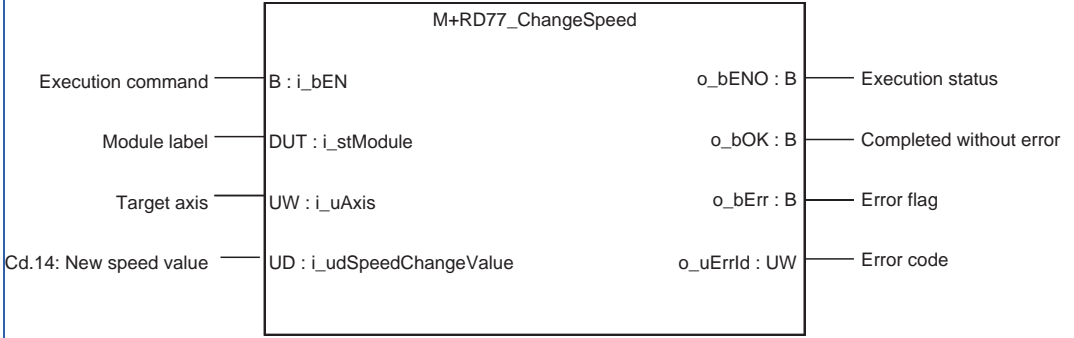
Item	Description	
Function overview	Changes the speed.	
Symbol		
Applicable hardware and software	Applicable module	RD77MS16, RD77MS8, RD77MS4, RD77MS2
	Applicable CPU	MELSEC iQ-R series
	Applicable engineering software	GX Works3
Programming language	Ladder	
Number of steps (maximum)	210 steps	
Function description	<ul style="list-style-type: none"> • By turning ON i_bEN (Execution command), the speed used for the control is changed to a new speed. • When the setting value of the target axis is out of the range, o_bErr (Error flag) turns ON, the FB processing is interrupted, and the error code 100 (Hexadecimal) is stored in o_uErrId (Error code). 	
Compiling method	Macro type	
FB operation type	Pulsed execution (multiple scan execution type)	

Item	Description
Timing chart	<p>When operation completes without an error</p> <p>When an error occurs</p>
Restrictions and precautions	<ul style="list-style-type: none"> • The FB does not include error recovery processing. Program the error recovery processing separately in accordance with the required system operation. • The FB cannot be used in an interrupt program. • Ensure that i_bEN (Execution command) is capable of being turned OFF by the program. Do not use this FB in programs that are only executed once such as a subroutine and FOR-NEXT loop because i_bEN (Execution command) cannot be turned OFF. • When this FB is used twice or more, precaution must be taken to avoid repetition of the target axis. • Every input must be provided with a value for proper FB operation. • When i_bEN (Execution command) is turned ON while the BUSY signal (X10 to X1F) is OFF, o_bErr (Error flag) turns ON, the FB processing is interrupted, and the error code 201 (Hexadecimal) is stored in o_uErrId (Error code).

Error codes

Error code	Description	Action
100 (Hexadecimal)	The setting value of i_uAxis (Target axis) is out of the range. The target axis is not within the range of 1 to 16.	Please try again after confirming the setting.
201 (Hexadecimal)	This FB is executed before positioning operation starts.	Please try again during positioning operation.

Labels

Input labels

Name	Variable name	Data type	Setting range	Description
Execution command	i_bEN	Bit	ON, OFF	ON: The FB is activated. OFF: The FB is not activated.
Module label	i_stModule	Structure	The setting range differs depending on the module label.	Specify the module label of the MELSEC iQ-R simple motion module.
Target axis	i_uAxis	Word [unsigned]	1 to 16	Specify the axis number. The setting range differs depending on the module used.
Cd.14: New speed value	i_udSpeedChangeValue	Double word [unsigned]	Pr.1: Unit setting = mm • 0 to 2000000000 Pr.1: Unit setting = inch • 0 to 2000000000 Pr.1: Unit setting = degree • 0 to 2000000000 Pr.1: Unit setting = pulse • 0 to 1000000000	Set a new speed.

Output labels

Name	Variable name	Data type	Default value	Description
Execution status	o_bENO	Bit	OFF	ON: The execution command is ON. OFF: The execution command is OFF.
Completed without error	o_bOK	Bit	OFF	When ON, it indicates that changing the speed has been completed.
Error flag	o_bErr	Bit	OFF	When ON, it indicates that an error has occurred in the FB.
Error code	o_uErrId	Word [unsigned]	0	The generated error code is stored.

Version upgrade history

Version	Date	Description
00D	2014/06/30	First edition

2.6 M+RD77_ChangeAccDecTime

Name

M+RD77_ChangeAccDecTime

Function overview

Item	Description	
Function overview	Changes the acceleration/deceleration time at a speed change.	
Symbol	<p>The diagram shows a rectangular block labeled 'M+RD77_ChangeAccDecTime'. On the left side, there are six input labels with lines pointing to the block: 'Execution command' (B : i_bEN), 'Module label' (DUT : i_stModule), 'Target axis' (UW : i_uAxis), 'Acceleration/deceleration time change enabled flag' (B : i_bEnable), 'Cd.10: New acceleration time value' (UD : i_udNewAccelerationTime), and 'Cd.11: New deceleration time value' (UD : i_udNewDecelerationTime). On the right side, there are four output labels with lines pointing from the block: 'Execution status' (o_bENO : B), 'Completed without error' (o_bOK : B), 'Error flag' (o_bErr : B), and 'Error code' (o_uErrId : UW).</p>	
Applicable hardware and software	Applicable module	RD77MS16, RD77MS8, RD77MS4, RD77MS2
	Applicable CPU	MELSEC iQ-R series
	Applicable engineering software	GX Works3
Programming language	Ladder	
Number of steps (maximum)	212 steps	
Function description	<ul style="list-style-type: none"> By turning ON i_bEN (Execution command), the setting of the acceleration/deceleration time is changed according to i_bEnable (Acceleration/deceleration time change enabled flag). When i_bEnable (Acceleration/deceleration time change enabled flag) is ON, i_udNewAccelerationTime (Cd.10: New acceleration time value) and i_udNewDecelerationTime (Cd.11: New deceleration time value) are set and Cd.12: Acceleration/deceleration time change during speed change, enable/disable selection is changed to 1: Enables modifications to acceleration/deceleration time. When i_bEnable (Acceleration/deceleration time change enabled flag) is OFF, i_udNewAccelerationTime (Cd.10: New acceleration time value) and i_udNewDecelerationTime (Cd.11: New deceleration time value) are not set and Cd.12: Acceleration/deceleration time change during speed change, enable/disable selection is changed to 0: Disables modifications to acceleration/deceleration time. When the setting value of the target axis is out of the range, o_bErr (Error flag) turns ON, the FB processing is interrupted, and the error code 100 (Hexadecimal) is stored in o_uErrId (Error code). 	
Compiling method	Macro type	
FB operation type	Pulsed execution (single scan execution type)	

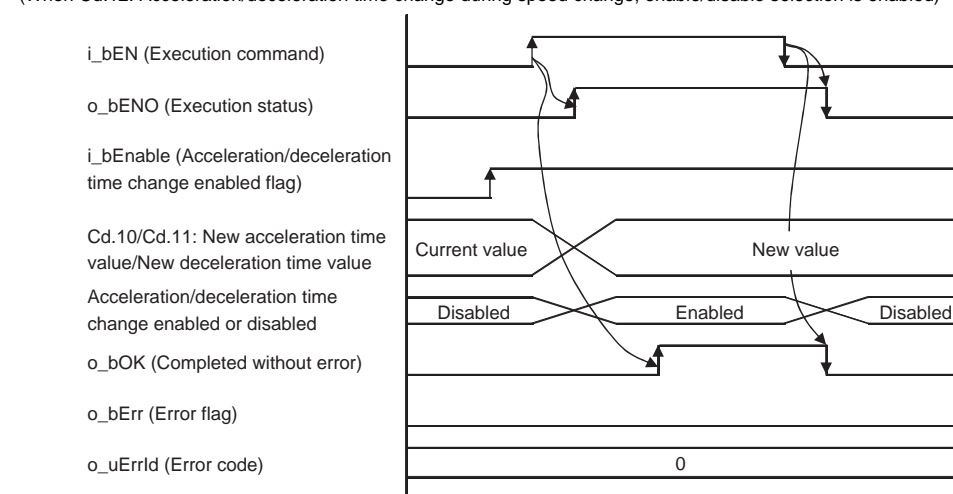
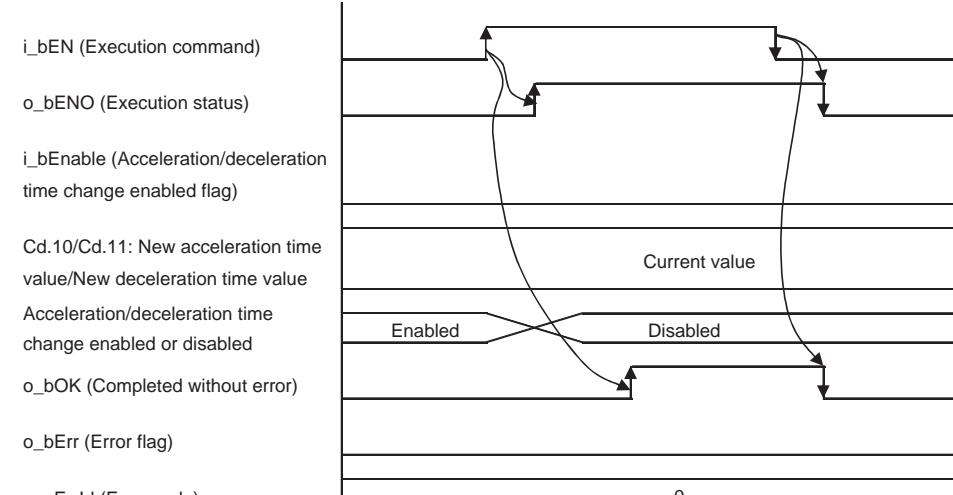
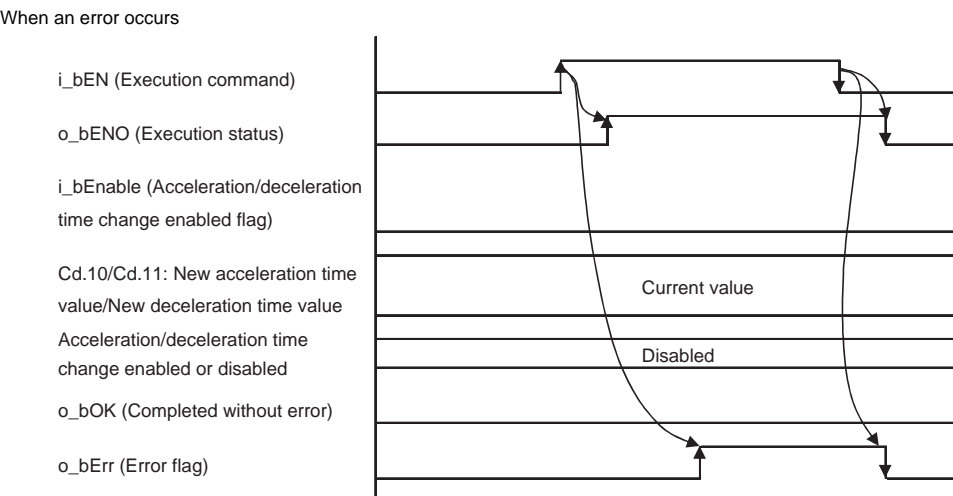
Item	Description
Timing chart	<p>When operation completes without an error</p> <ul style="list-style-type: none"> (When Cd.12: Acceleration/deceleration time change during speed change, enable/disable selection is enabled)  <ul style="list-style-type: none"> (When Cd.12: Acceleration/deceleration time change during speed change, enable/disable selection is disabled)  <p>When an error occurs</p> 

Item	Description
Restrictions and precautions	<ul style="list-style-type: none"> The FB does not include error recovery processing. Program the error recovery processing separately in accordance with the required system operation. The FB cannot be used in an interrupt program. Ensure that i_bEN (Execution command) is capable of being turned OFF by the program. Do not use this FB in programs that are only executed once such as a subroutine and FOR-NEXT loop because i_bEN (Execution command) cannot be turned OFF. When this FB is used twice or more, precaution must be taken to avoid repetition of the target axis. A duplicated coil warning may occur during compile operation. However, this is not a problem and the FB will operate without an error. Every input must be provided with a value for proper FB operation.

Error codes

Error code	Description	Action
100 (Hexadecimal)	The setting value of i_uAxis (Target axis) is out of the range. The target axis is not within the range of 1 to 16.	Please try again after confirming the setting.

Labels

Input labels

Name	Variable name	Data type	Setting range	Description
Execution command	i_bEN	Bit	ON, OFF	ON: The FB is activated. OFF: The FB is not activated.
Module label	i_stModule	Structure	The setting range differs depending on the module label.	Specify the module label of the MELSEC iQ-R simple motion module.
Target axis	i_uAxis	Word [unsigned]	1 to 16	Specify the axis number. The setting range differs depending on the module used.
Acceleration/ deceleration time change enabled flag	i_bEnable	Bit	ON: Enabled OFF: Disabled	Set this label to enable or disable acceleration/deceleration time changes.
Cd.10: New acceleration time value	i_udNewAcceleratio nTime	Double word [unsigned]	0 to 8,388,608 (ms)	Set a new acceleration time. When 0 is set, the acceleration time is not changed after the speed is changed. In this case, the previously set acceleration time is applied to the control.
Cd.11: New deceleration time value	i_udNewDeceleratio nTime	Double word [unsigned]	0 to 8,388,608 (ms)	Set a new deceleration time. When 0 is set, the deceleration time is not changed after the speed is changed. In this case, the previously set deceleration time is applied to the control.

Output labels

Name	Variable name	Data type	Default value	Description
Execution status	o_bENO	Bit	OFF	ON: The execution command is ON. OFF: The execution command is OFF.
Completed without error	o_bOK	Bit	OFF	When ON, it indicates that setting acceleration/deceleration time change has been completed.
Error flag	o_bErr	Bit	OFF	When ON, it indicates that an error has occurred in the FB.
Error code	o_uErrId	Word [unsigned]	0	The error code generated in the FB is stored.

Version upgrade history

Version	Date	Description
00D	2014/06/30	First edition

2.7 M+RD77_ChangePosition

Name

M+RD77_ChangePosition

Function overview

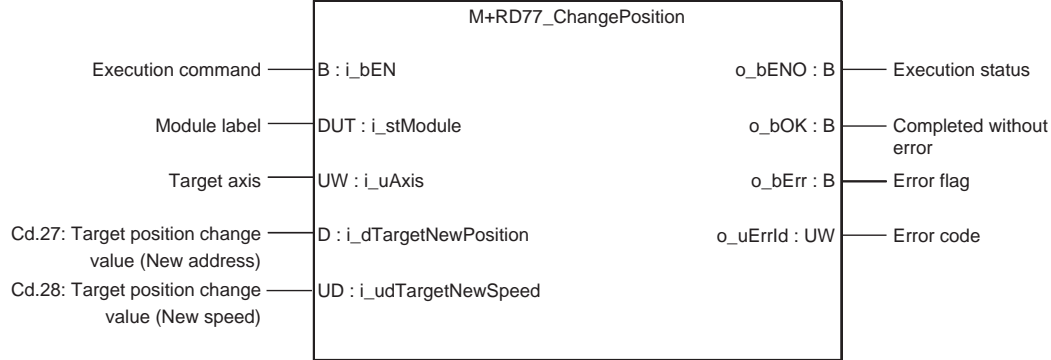
Item	Description	
Function overview	Changes the target position.	
Symbol		
Applicable hardware and software	Applicable module	RD77MS16, RD77MS8, RD77MS4, RD77MS2
	Applicable CPU	MELSEC iQ-R series
	Applicable engineering software	GX Works3
Programming language	Ladder	
Number of steps (maximum)	254 steps	
Function description	<ul style="list-style-type: none"> By turning ON i_bEN (Execution command), the target position is changed according to the value set in i_dTargetNewPosition (Cd.27: Target position change value (New address)) and the speed is changed according to the value set in i_udTargetNewSpeed (Cd.28: Target position change value (New speed)) during position control. When the setting value of the target axis is out of the range, o_bErr (Error flag) turns ON, the FB processing is interrupted, and the error code 100 (Hexadecimal) is stored in o_uErrId (Error code). 	
Compiling method	Macro type	
FB operation type	Pulsed execution (multiple scan execution type)	

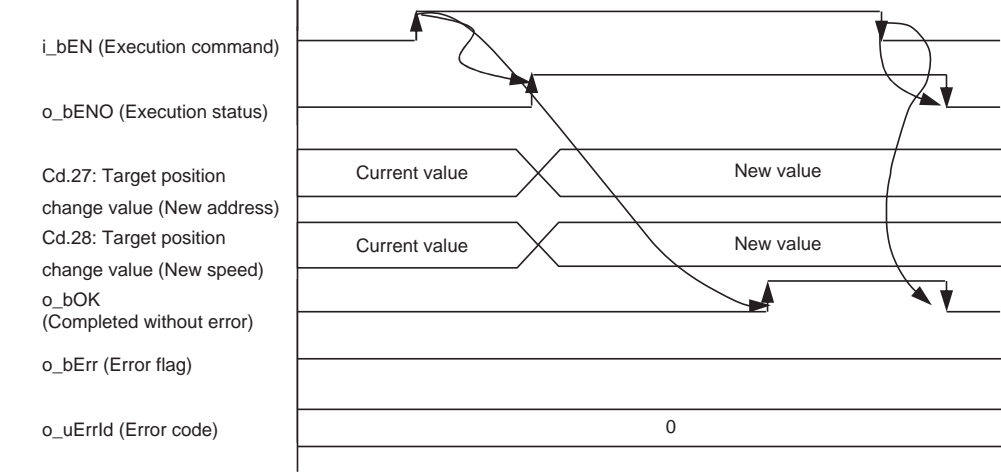
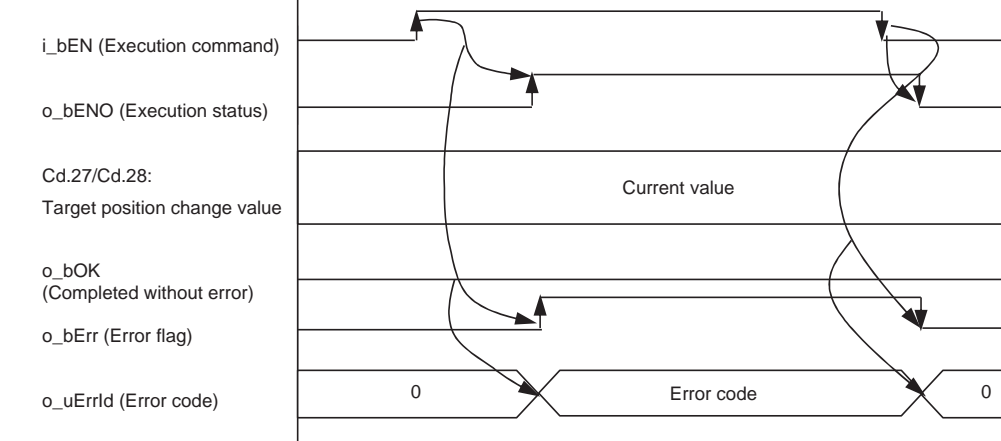
Item	Description
Timing chart	<p>When operation completes without an error</p>  <p>When an error occurs</p> 
Restrictions and precautions	<ul style="list-style-type: none"> • The FB does not include error recovery processing. Program the error recovery processing separately in accordance with the required system operation. • The FB cannot be used in an interrupt program. • Ensure that i_bEN (Execution command) is capable of being turned OFF by the program. Do not use this FB in programs that are only executed once such as a subroutine and FOR-NEXT loop because i_bEN (Execution command) cannot be turned OFF. • When this FB is used twice or more, precaution must be taken to avoid repetition of the target axis. • Every input must be provided with a value for proper FB operation. • When i_bEN (Execution command) is turned ON while the BUSY signal (X10 to X1F) is OFF, o_bErr (Error flag) turns ON, the FB processing is interrupted, and the error code 201 (Hexadecimal) is stored in o_uErrId (Error code).

Error codes

Error code	Description	Action
100 (Hexadecimal)	The setting value of i_uAxis (Target axis) is out of the range. The target axis is not within the range of 1 to 16.	Please try again after confirming the setting.
201 (Hexadecimal)	This FB is executed before positioning operation starts.	Please try again during positioning operation.

Labels

Input labels

Name	Variable name	Data type	Setting range	Description
Execution command	i_bEN	Bit	ON, OFF	ON: The FB is activated. OFF: The FB is not activated.
Module label	i_stModule	Structure	The setting range differs depending on the module label.	Specify the module label of the MELSEC iQ-R simple motion module.
Target axis	i_uAxis	Word [unsigned]	1 to 16	Specify the axis number. The setting range differs depending on the module used.
Cd.27: Target position change value (New address)	i_dTargetNewPosition	Double word [signed]	Pr.1: Unit setting = mm • ABS: -2147483648 to +2147483647 • INC: -2147483648 to +2147483647 Pr.1: Unit setting = inch • ABS: -2147483648 to +2147483647 • INC: -2147483648 to +2147483647 Pr.1: Unit setting = degree • ABS: 0 to 35999999 • INC: -2147483648 to +2147483647 Pr.1: Unit setting = pulse • ABS: -2147483648 to +2147483647 • INC: -2147483648 to +2147483647	Set the new positioning address when changing the target position during positioning operation.
Cd.28: Target position change value (New speed)	i_udTargetNewSpeed	Double word [unsigned]	Pr.1: Unit setting = mm • 0 to 2000000000 Pr.1: Unit setting = inch • 0 to 2000000000 Pr.1: Unit setting = degree • 0 to 2000000000 Pr.1: Unit setting = pulse • 0 to 1000000000	Set the new speed when changing the target position during positioning operation. When 0 is set, the speed is not changed.

Output labels

Name	Variable name	Data type	Default value	Description
Execution status	o_bENO	Bit	OFF	ON: The execution command is ON. OFF: The execution command is OFF.
Completed without error	o_bOK	Bit	OFF	When ON, it indicates that the module has accepted the target position change values.
Error flag	o_bErr	Bit	OFF	When ON, it indicates that an error has occurred in the FB.
Error code	o_uErrId	Word [unsigned]	0	The generated error code is stored.

Version upgrade history

Version	Date	Description
00D	2014/06/30	First edition

2.8 M+RD77_Restart

Name

M+RD77_Restart

Function overview

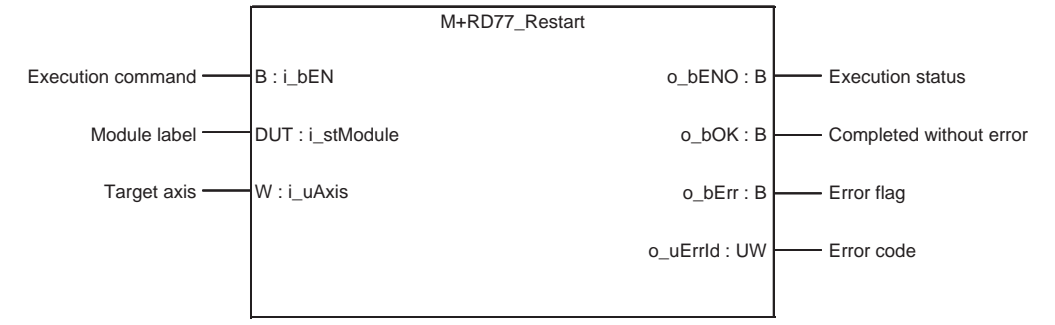
Item	Description	
Function overview	Restarts the axis being stopped.	
Symbol		
Applicable hardware and software	Applicable module	RD77MS16, RD77MS8, RD77MS4, RD77MS2
	Applicable CPU	MELSEC iQ-R series
	Applicable engineering software	GX Works3
Programming language	Ladder	
Number of steps (maximum)	263 steps	
Function description	<ul style="list-style-type: none"> • Only when the conditions are met, the positioning operation that is stopped due to an error is restarted by turning ON i_bEN (Execution command). The conditions are the following: the positioning complete signal (Md.31: Status) is OFF and the axis operation status is a stop. When any of the conditions is not met, o_bErr (Error flag) turns ON, the FB processing is interrupted, and the error code 202 (Hexadecimal) is stored in o_uErrId (Error code). • When the setting value of the target axis is out of the range, o_bErr (Error flag) turns ON, the FB processing is interrupted, and the error code 100 (Hexadecimal) is stored in o_uErrId (Error code). 	
Compiling method	Macro type	
FB operation type	Pulsed execution (multiple scan execution type)	

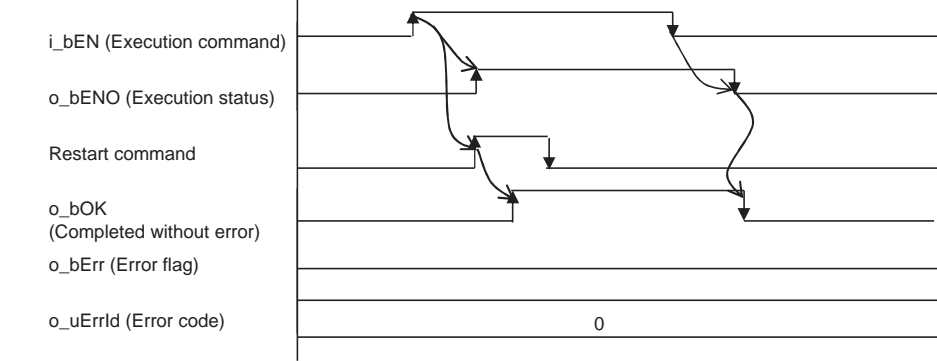
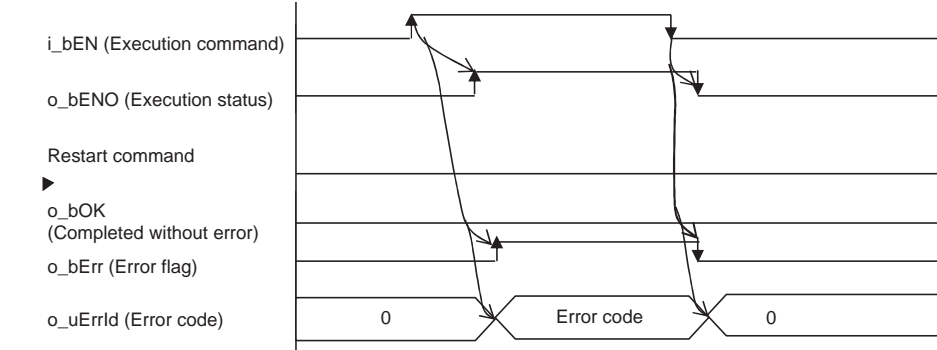
Item	Description
Timing chart	<p>When operation completes without an error</p>  <p>When an error occurs</p> 
Restrictions and precautions	<ul style="list-style-type: none"> • The FB does not include error recovery processing. Program the error recovery processing separately in accordance with the required system operation. • The FB cannot be used in an interrupt program. • Ensure that i_bEN (Execution command) is capable of being turned OFF by the program. Do not use this FB in programs that are only executed once such as a subroutine and FOR-NEXT loop because i_bEN (Execution command) cannot be turned OFF. • When this FB is used twice or more, precaution must be taken to avoid repetition of the target axis. • Every input must be provided with a value for proper FB operation.

Error codes

Error code	Description	Action
100 (Hexadecimal)	The setting value of i_uAxis (Target axis) is out of the range. The target axis is not within the range of 1 to 16.	Please try again after confirming the setting.
202 (Hexadecimal)	The conditions for positioning restart are not met. Any of the following conditions is not met. <ul style="list-style-type: none"> Positioning complete signal: Off Axis operation status: Stop 	Please try again after confirming the setting. <ul style="list-style-type: none"> Positioning complete signal: Off Axis operation status: Stop

Labels

Input labels

Name	Variable name	Data type	Setting range	Description
Execution command	i_bEN	Bit	ON, OFF	ON: The FB is activated. OFF: The FB is not activated.
Module label	i_stModule	Structure	The setting range differs depending on the module label.	Specify the module label of the MELSEC iQ-R simple motion module.
Target axis	i_uAxis	Word [unsigned]	1 to 16	Specify the axis number. The setting range differs depending on the module used.

Output labels

Name	Variable name	Data type	Default value	Description
Execution status	o_bENO	Bit	OFF	ON: The execution command is ON. OFF: The execution command is OFF.
Completed without error	o_bOK	Bit	OFF	When ON, it indicates that the module has accepted the restart command request.
Error flag	o_bErr	Bit	OFF	When ON, it indicates that an error has occurred in the FB.
Error code	o_uErrId	Word [unsigned]	0	The generated error code is stored.

Version upgrade history

Version	Date	Description
00D	2014/06/30	First edition

2.9 M+RD77_OperateError

Name

M+RD77_OperateError

Function overview

Item	Description	
Function overview	Monitors errors and warnings, and resets errors.	
Symbol	<p>The diagram shows a block titled 'M+RD77_OperateError'. On the left side, there are four input lines: 'Execution command' connected to 'B : i_bEN', 'Module label' connected to 'DUT : i_stModule', 'Target axis' connected to 'UW : i_uAxis', and 'Error reset command' connected to 'B : i_bErrReset'. On the right side, there are eight output lines: 'o_bENO : B' (Execution status), 'o_bOK : B' (Completed without error), 'o_bModuleErr : B' (Axis error detection), 'o_uModuleErrId : UW' (Axis error code), 'o_bModuleWarn : B' (Axis warning detection), 'o_uModuleWarnId : UW' (Axis warning code), 'o_bErr : B' (Error flag), and 'o_uErrId : UW' (Error code).</p>	
Applicable hardware and software	Applicable module	RD77MS16, RD77MS8, RD77MS4, RD77MS2
	Applicable CPU	MELSEC iQ-R series
	Applicable engineering software	GX Works3
Programming language	Ladder	
Number of steps (maximum)	407 steps	
Function description	<ul style="list-style-type: none"> • By turning ON i_bEN (Execution command), errors of the target axis are monitored. • When a module error occurs, an error code is stored in o_uModuleErrId (Axis error code). • After i_bEN (Execution command) is turned ON, the generated error is reset by turning ON i_bErrReset (Error reset command). • When a warning occurs in the module, the warning can be reset by turning ON i_bErrReset (Error reset command). • When the setting value of the target axis is out of the range, o_bErr (Error flag) turns ON, the FB processing is interrupted, and the error code 100 (Hexadecimal) is stored in o_uErrId (Error code). 	
Compiling method	Macro type	
FB operation type	Real-time execution	

Item	Description
Timing chart	<p>When operation completes without an error</p> <p>When an error occurs</p>
Restrictions and precautions	<ul style="list-style-type: none"> • The FB does not include error recovery processing. Program the error recovery processing separately in accordance with the required system operation. • The FB cannot be used in an interrupt program. • Ensure that i_bEN (Execution command) is capable of being turned OFF by the program. Do not use this FB in programs that are only executed once such as a subroutine and FOR-NEXT loop because i_bEN (Execution command) cannot be turned OFF. • When this FB is used twice or more, precaution must be taken to avoid repetition of the target axis. • Do not change i_uAxis (Target axis) while i_bEN (Execution command) is ON. • Every input must be provided with a value for proper FB operation.

Error codes

Error code	Description	Action
100 (Hexadecimal)	The setting value of i_uAxis (Target axis) is out of the range. The target axis is not within the range of 1 to 16.	Please try again after confirming the setting.

Labels

Input labels

Name	Variable name	Data type	Setting range	Description
Execution command	i_bEN	Bit	ON, OFF	ON: The FB is activated. OFF: The FB is not activated.
Module label	i_stModule	Structure	The setting range differs depending on the module label.	Specify the module label of the MELSEC iQ-R simple motion module.
Target axis	i_uAxis	Word [unsigned]	1 to 16	Specify the axis number. The setting range differs depending on the module used.
Error reset command	i_bErrReset	Bit	ON, OFF	ON: Errors are reset. OFF: Errors are not reset.

Output labels

Name	Variable name	Data type	Default value	Description
Execution status	o_bENO	Bit	OFF	ON: The execution command is ON. OFF: The execution command is OFF.
Completed without error	o_bOK	Bit	OFF	When ON, it indicates that resetting the error has been completed.
Axis error detection	o_bModuleErr	Bit	OFF	When ON, it indicates that an axis error has occurred.
Axis error code	o_uModuleErrId	Word [unsigned]	0	An error code of an error that has occurred in the module of the specified axis is stored.
Axis warning detection	o_bModuleWarn	Bit	OFF	When ON, it indicates that an axis warning has occurred.
Axis warning code	o_uModuleWarnId	Word [unsigned]	0	A warning code of a warning that has occurred in the module of the specified axis is stored.
Error flag	o_bErr	Bit	OFF	When ON, it indicates that an error has occurred in the FB.
Error code	o_uErrId	Word [unsigned]	0	The generated error code is stored.

Version upgrade history

Version	Date	Description
00D	2014/06/30	First edition

2.10 M+RD77_InitializeParameter

Name

M+RD77_InitializeParameter

Function overview

Item	Description
Function overview	Initializes the parameter.

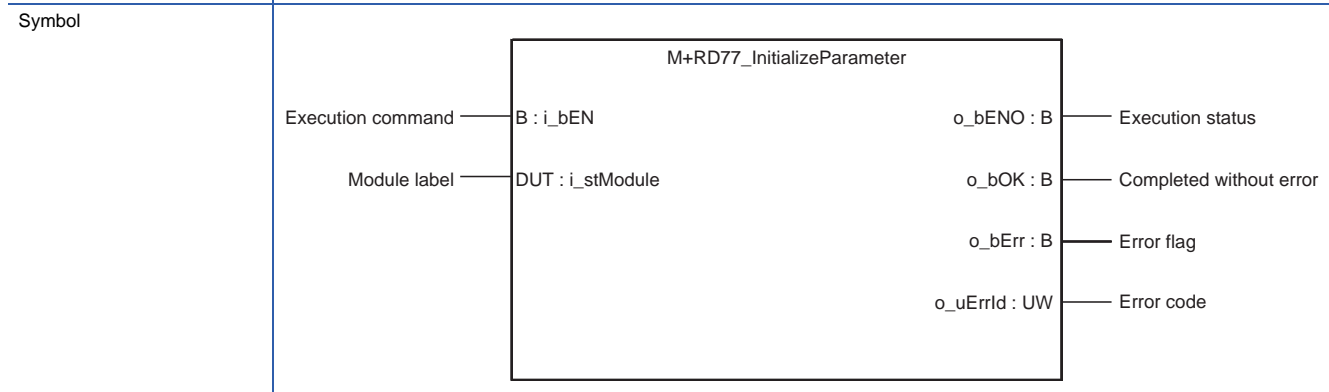

Applicable hardware and software	Applicable module	RD77MS16, RD77MS8, RD77MS4, RD77MS2
	Applicable CPU	MELSEC iQ-R series
	Applicable engineering software	GX Works3

Programming language: Ladder

Number of steps (maximum): 45 steps

Function description: By turning ON i_bEN (Execution command), the setting data stored in the buffer memory and the flash ROM of the RD77 is reset to the factory setting.

Compiling method: Macro type

FB operation type: Pulsed execution (multiple scan execution type)

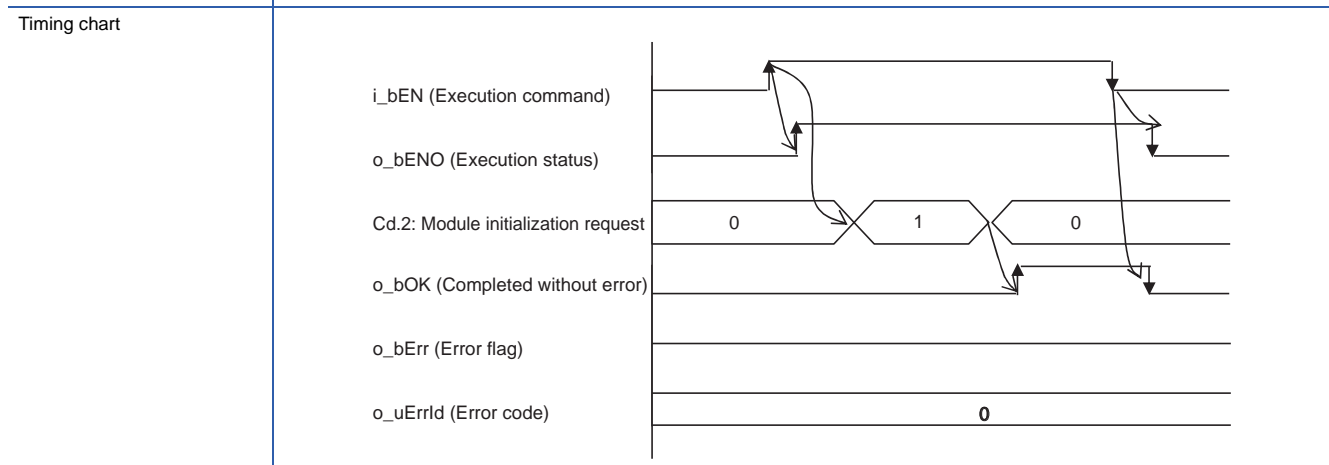

- Restrictions and precautions
- The FB does not include error recovery processing. Program the error recovery processing separately in accordance with the required system operation.
 - The FB cannot be used in an interrupt program.
 - Ensure that i_bEN (Execution command) is capable of being turned OFF by the program. Do not use this FB in programs that are only executed once such as a subroutine and FOR-NEXT loop because i_bEN (Execution command) cannot be turned OFF.
 - Every input must be provided with a value for proper FB operation.
 - Before using this FB, make sure that the PLC READY signal (Y0) is OFF.
 - After the setting data is initialized, reset the CPU module or restart the power of the programmable controller.

Error codes

Error code	Description	Action
None	None	None

Labels

■Input labels

Name	Variable name	Data type	Setting range	Description
Execution command	i_bEN	Bit	ON, OFF	ON: The FB is activated. OFF: The FB is not activated.
Module label	i_stModule	Structure	The setting range differs depending on the module label.	Specify the module label of the MELSEC iQ-R simple motion module.

■Output labels

Name	Variable name	Data type	Default value	Description
Execution status	o_bENO	Bit	OFF	ON: The execution command is ON. OFF: The execution command is OFF.
Completed without error	o_bOK	Bit	OFF	When ON, it indicates that initializing the parameter has been completed.
Error flag	o_bErr	Bit	OFF	Always OFF
Error code	o_uErrId	Word [unsigned]	0	Always 0

Version upgrade history

Version	Date	Description
00D	2014/06/30	First edition

2.11 M+RD77_WriteFlash

Name

M+RD77_WriteFlash

Function overview

Item	Description
Function overview	Writes the parameter, positioning data, and block start data in the buffer memory to the flash ROM.

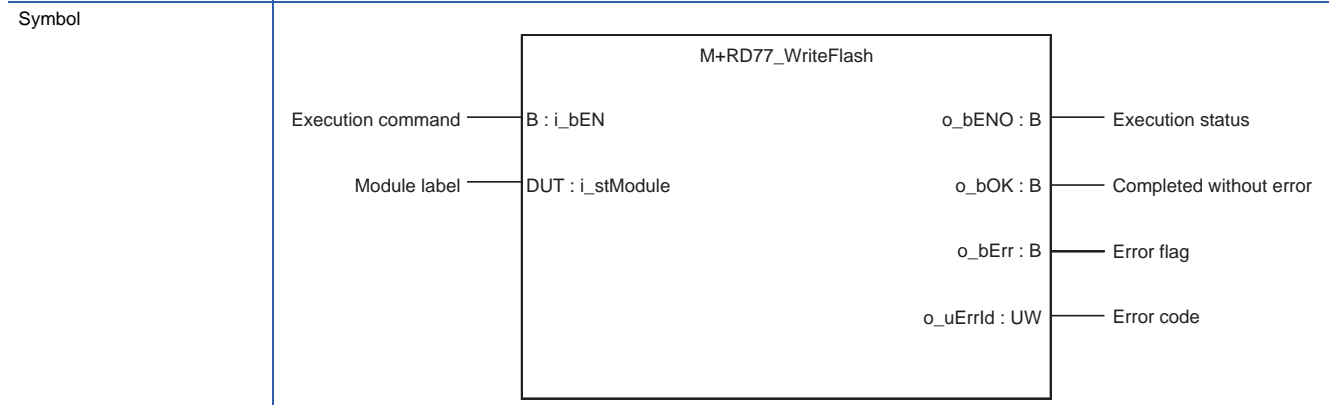

Applicable hardware and software	Applicable module	RD77MS16, RD77MS8, RD77MS4, RD77MS2
	Applicable CPU	MELSEC iQ-R series
	Applicable engineering software	GX Works3

Programming language	Ladder
----------------------	--------

Number of steps (maximum)	45 steps
---------------------------	----------

Function description	By turning ON i_bEN (Execution command), the setting data in the buffer memory is written to the flash ROM.
----------------------	---

Compiling method	Macro type
------------------	------------

FB operation type	Pulsed execution (multiple scan execution type)
-------------------	---

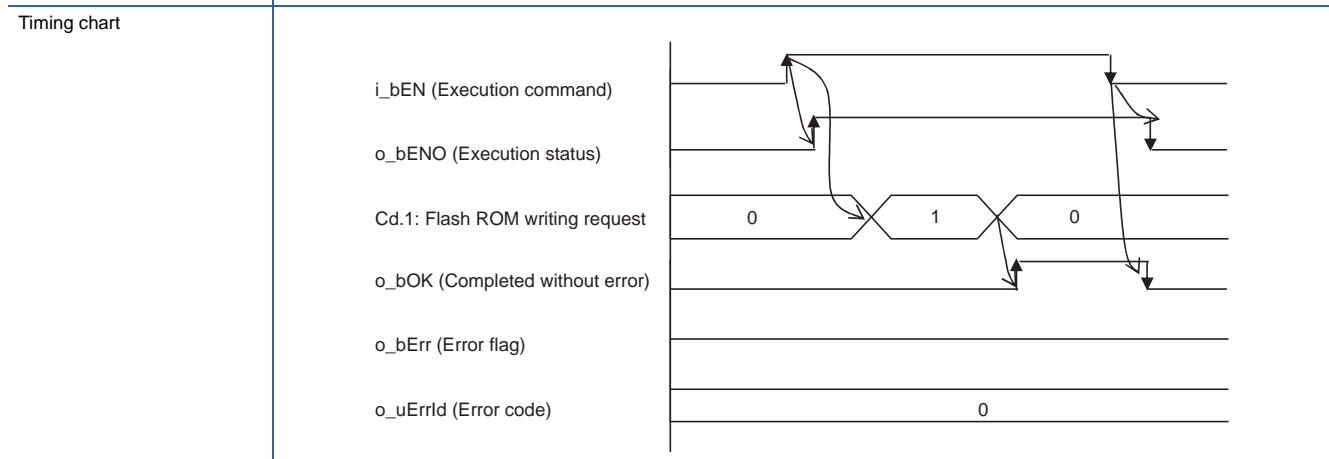

Restrictions and precautions	<ul style="list-style-type: none"> • The FB does not include error recovery processing. Program the error recovery processing separately in accordance with the required system operation. • The FB cannot be used in an interrupt program. • Ensure that i_bEN (Execution command) is capable of being turned OFF by the program. Do not use this FB in programs that are only executed once such as a subroutine and FOR-NEXT loop because i_bEN (Execution command) cannot be turned OFF. • Every input must be provided with a value for proper FB operation. • Before using this FB, make sure that the PLC READY signal (Y0) is OFF.
------------------------------	---

Error codes

Error code	Description	Action
None	None	None

Labels

■Input labels

Name	Variable name	Data type	Setting range	Description
Execution command	i_bEN	Bit	ON, OFF	ON: The FB is activated. OFF: The FB is not activated.
Module label	i_stModule	Structure	The setting range differs depending on the module label.	Specify the module label of the MELSEC iQ-R simple motion module.

■Output labels

Name	Variable name	Data type	Default value	Description
Execution status	o_bENO	Bit	OFF	ON: The execution command is ON. OFF: The execution command is OFF.
Completed without error	o_bOK	Bit	OFF	When ON, it indicates that writing the setting data to the flash ROM has been completed.
Error flag	o_bErr	Bit	OFF	Always OFF
Error code	o_uErrId	Word [unsigned]	0	Always 0

Version upgrade history

Version	Date	Description
00D	2014/06/30	First edition

2.12 M+RD77_ChangeServoParameter

Name

M+RD77_ChangeServoParameter

Function overview

Item	Description	
Function overview	Changes the servo parameter after the amplifier is activated.	
Symbol		
Applicable hardware and software	Applicable module	RD77MS16, RD77MS8, RD77MS4, RD77MS2
	Applicable CPU	MELSEC iQ-R series
	Applicable engineering software	GX Works3
Programming language	Ladder	
Number of steps (maximum)	236 steps	
Function description	<ul style="list-style-type: none"> By turning ON i_bEN (Execution command), the servo parameter after the amplifier is started is changed. When the target axis of the input label is incorrectly set, o_bErr turns ON and the error code is stored in o_bErrId. 	
Compiling method	Macro type	
FB operation type	Pulsed execution (multiple scan execution type)	

Item	Description
Timing chart	<p>When operation completes without an error</p> <p>When an error occurs</p>

Restrictions and precautions	<ul style="list-style-type: none"> • The FB does not include error recovery processing. Program the error recovery processing separately in accordance with the required system operation. • The FB cannot be used in an interrupt program. • Ensure that i_bEN (Execution command) is capable of being turned OFF by the program. Do not use this FB in programs that are only executed once such as a subroutine and FOR-NEXT loop because i_bEN (Execution command) cannot be turned OFF. • When this FB is used twice or more, precaution must be taken to avoid repetition of the target axis. • Every input must be provided with a value for proper FB operation. • Before using this FB, make sure that communication with the servo amplifier is established. • When this FB fails writing the parameter, o_bOK (Completed without error) does not turn ON. • The setting items and range differ depending on the module used in the system.
------------------------------	---

Error codes

Error code	Description	Action
100 (Hexadecimal)	The setting value of i_uAxis (Target axis) is out of the range. The target axis is not within the range of 1 to 16.	Please try again after confirming the setting.

Labels

Input labels

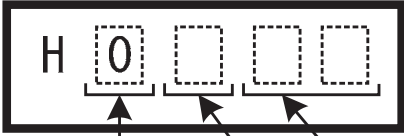
Name	Variable name	Data type	Setting range	Description
Execution command	i_bEN	Bit	ON, OFF	ON: The FB is activated. OFF: The FB is not activated.
Module label	i_stModule	Structure	The setting range differs depending on the module label.	Specify the module label of the MELSEC iQ-R simple motion module.
Target axis	i_uAxis	Word [unsigned]	1 to 16	Specify the axis number. The setting range differs depending on the module used.
Cd.131: Parameter No.	i_uParameterNo	Word [unsigned]	H0001 to H0C40	<p>Set the servo parameter number to be changed. Set the data in the same specifications as [Cd.131] of the system control data. Even when the data No. different from the data specifications of [Cd.131] is specified, the execution of this FB is completed normally. In this case, an error may occur in the simple motion module. The following figure shows the data specifications of [Cd.131].</p> <p>Setting value</p>  <p>Writing mode 0: Writing to the RAM</p> <p>Parameter No. setting 01h to 40h</p> <p>Parameter group 0: PA group 1: PB group 2: PC group 3: PD group 4: PE group 5: PF group 9: PO group A: PS group B: PL group C: PT group</p>
Cd.132: Change data	i_dChangeValue	Double word [signed]	Refer to the Servo Amplifier Instruction Manual.	Set the servo parameter value to be changed.

Output labels

Name	Variable name	Data type	Default value	Description
Execution status	o_bENO	Bit	OFF	ON: The execution command is ON. OFF: The execution command is OFF.
Completed without error	o_bOK	Bit	OFF	When ON, it indicates that changing the servo parameter has been completed.
Error flag	o_bErr	Bit	OFF	When ON, it indicates that an error has occurred in the FB.
Error code	o_uErrId	Word [unsigned]	0	The error code generated in the FB is stored.

Version upgrade history

Version	Date	Description
00D	2014/06/30	First edition

2.13 M+RD77_ChangeTorqueControlMode

Name

M+RD77_ChangeTorqueControlMode

Function overview

Item	Description	
Function overview	Activates the torque control mode.	
Symbol	<p>The diagram shows a function block titled 'M+RD77_ChangeTorqueControlMode'. On the left side, there are several input terminals: 'B : i_bEN' (Execution command), 'DUT : i_stModule' (Module label), 'UW : i_uAxis' (Target axis), 'W : i_wCommandTorque' (Cd.143: Command torque at torque control mode), 'UW : i_uTorqueTimeConstDrivingMode' (Cd.144: Torque time constant at torque control mode (Forward direction)), 'UW : i_uTorqueTimeConstRegenerativeMode' (Cd.145: Torque time constant at torque control mode (Negative direction)), and 'UD : i_udSpeedLimit' (Cd.146: Speed limit value at torque control mode). On the right side, there are several output terminals: 'o_bENO : B' (Execution status), 'o_bOK : B' (Completed without error), 'o_bErr : B' (Error flag), and 'o_uErrId : UW' (Error code).</p>	
Applicable hardware and software	Applicable module	RD77MS16, RD77MS8, RD77MS4, RD77MS2
	Applicable CPU	MELSEC iQ-R series
	Applicable engineering software	GX Works3
Programming language	Ladder	
Number of steps (maximum)	347 steps	
Function description	<ul style="list-style-type: none"> • By turning ON i_bEN (Execution command), the torque control mode is activated for the specified axis. • When this FB is executed under torque control, the command torque and speed limit value are changed. • When the setting value of the target axis is out of the range, o_bErr (Error flag) turns ON, the FB processing is interrupted, and the error code 100 (Hexadecimal) is stored in o_uErrId (Error code). 	
Compiling method	Macro type	
FB operation type	Pulsed execution (multiple scan execution type)	

Item	Description
Timing chart	<p>When operation completes without an error</p> <p>When an error occurs</p>
Restrictions and precautions	<ul style="list-style-type: none"> • The FB does not include error recovery processing. Program the error recovery processing separately in accordance with the required system operation. • The FB cannot be used in an interrupt program. • Ensure that i_bEN (Execution command) is capable of being turned OFF by the program. Do not use this FB in programs that are only executed once such as a subroutine and FOR-NEXT loop because i_bEN (Execution command) cannot be turned OFF. • When this FB is used twice or more, precaution must be taken to avoid repetition of the target axis. • Every input must be provided with a value for proper FB operation. • When this FB fails switching the mode, o_bOK (Completed without error) does not turn ON.

Error codes

Error code	Description	Action
100 (Hexadecimal)	The setting value of i_uAxis (Target axis) is out of the range. The target axis is not within the range of 1 to 16.	Please try again after confirming the setting.

Labels

■ Input labels

Name	Variable name	Data type	Setting range	Description
Execution command	i_bEN	Bit	ON, OFF	ON: The FB is activated. OFF: The FB is not activated.
Module label	i_stModule	Structure	The setting range differs depending on the module label.	Specify the module label of the MELSEC iQ-R simple motion module.
Target axis	i_uAxis	Word [unsigned]	1 to 16	Specify the axis number. The setting range differs depending on the module used.
Cd.143: Command torque at torque control mode	i_wCommandTorque	Word [signed]	-10000 to 10000	Set the command torque at torque control mode.
Cd.144: Torque time constant at torque control mode (Forward direction)	i_uTorqueTimeConstDrivingMode	Word [unsigned]	0 to 65535 (0 to 32767: Set by decimal number. 32768 to 65535: Convert the number to hexadecimal number and set.)	Set the time constant for the driving of torque control mode.
Cd.145: Torque time constant at torque control mode (Negative direction)	i_uTorqueTimeConstRegenerativeMode	Word [unsigned]	0 to 65535 (0 to 32767: Set by decimal number. 32768 to 65535: Convert the number to hexadecimal number and set.)	Set the time constant for the regeneration of torque control mode.
Cd.146: Speed limit value at torque control mode	i_udSpeedLimit	Double word [unsigned]	Pr.1: Unit setting = mm • 0 to 2000000000 Pr.1: Unit setting = inch • 0 to 2000000000 Pr.1: Unit setting = degree • 0 to 2000000000 Pr.1: Unit setting = pulse • 0 to 1000000000	Set the speed limit value at torque control mode.

■ Output labels

Name	Variable name	Data type	Default value	Description
Execution status	o_bENO	Bit	OFF	ON: The execution command is ON. OFF: The execution command is OFF.
Completed without error	o_bOK	Bit	OFF	When ON, it indicates that changing control mode has been completed.
Error flag	o_bErr	Bit	OFF	When ON, it indicates that an error has occurred in the FB.
Error code	o_uErrId	Word [unsigned]	0	The error code generated in the FB is stored.

Version upgrade history

Version	Date	Description
00D	2014/06/30	First edition

2.14 M+RD77_ChangeSpeedControlMode

Name

M+RD77_ChangeSpeedControlMode

Function overview

Item	Description	
Function overview	Activates the speed control mode.	
Symbol	<p>The diagram shows a function block titled 'M+RD77_ChangeSpeedControlMode'. On the left side, there are four inputs: 'B : i_bEN' (Execution command), 'DUT : i_stModule' (Module label), 'UW : i_uAxis' (Target axis), and 'D : i_dCommandSpeed' (Cd.140: Command speed at speed control mode). On the right side, there are four outputs: 'o_bENO : B' (Execution status), 'o_bOK : B' (Completed without error), 'o_bErr : B' (Error flag), and 'o_uErrId : UW' (Error code). Below the main block, there are three additional inputs: 'UW : i_uSpeedAccelerationTime' (Cd.141: Acceleration time at speed control mode) and 'UW : i_uSpeedDecelerationTime' (Cd.142: Deceleration time at speed control mode).</p>	
Applicable hardware and software	Applicable module	RD77MS16, RD77MS8, RD77MS4, RD77MS2
	Applicable CPU	MELSEC iQ-R series
	Applicable engineering software	GX Works3
Programming language	Ladder	
Number of steps (maximum)	303 steps	
Function description	<ul style="list-style-type: none"> • By turning ON i_bEN (Execution command), the speed control mode is activated for the specified axis. • When this FB is executed under speed control, the command speed is changed. • When the setting value of the target axis is out of the range, o_bErr (Error flag) turns ON, the FB processing is interrupted, and the error code 100 (Hexadecimal) is stored in o_uErrId (Error code). 	
Compiling method	Macro type	
FB operation type	Pulsed execution (multiple scan execution type)	

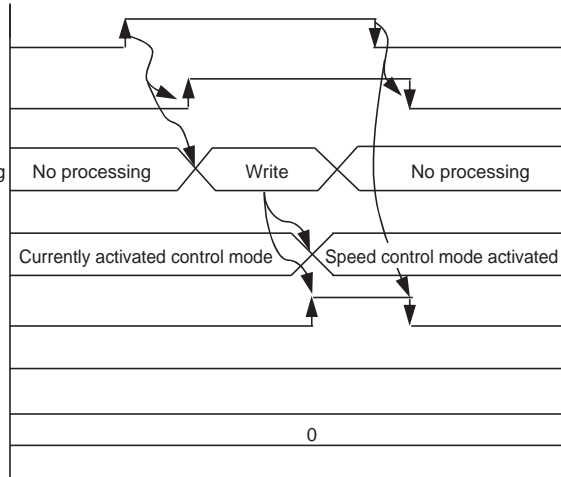
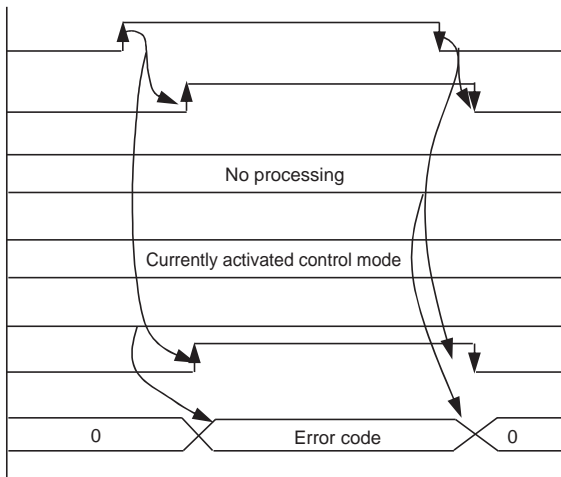
Item	Description
Timing chart	<p>When operation completes without an error</p>  <p>When an error occurs</p> 
Restrictions and precautions	<ul style="list-style-type: none"> • The FB does not include error recovery processing. Program the error recovery processing separately in accordance with the required system operation. • The FB cannot be used in an interrupt program. • Ensure that i_bEN (Execution command) is capable of being turned OFF by the program. Do not use this FB in programs that are only executed once such as a subroutine and FOR-NEXT loop because i_bEN (Execution command) cannot be turned OFF. • When this FB is used twice or more, precaution must be taken to avoid repetition of the target axis. • Every input must be provided with a value for proper FB operation. • When this FB fails switching the mode, o_bOK (Completed without error) does not turn ON.

Error codes

Error code	Description	Action
100 (Hexadecimal)	The setting value of i_uAxis (Target axis) is out of the range. The target axis is not within the range of 1 to 16.	Please try again after confirming the setting.

Labels

Input labels

Name	Variable name	Data type	Setting range	Description
Execution command	i_bEN	Bit	ON, OFF	ON: The FB is activated. OFF: The FB is not activated.
Module label	i_stModule	Structure	The setting range differs depending on the module label.	Specify the module label of the MELSEC iQ-R simple motion module.
Target axis	i_uAxis	Word [unsigned]	1 to 16	Specify the axis number. The setting range differs depending on the module used.
Cd.140: Command speed at speed control mode	i_dCommandSpeed	Double word [signed]	Pr.1: Unit setting = mm • -2000000000 to +2000000000 Pr.1: Unit setting = inch • -2000000000 to +2000000000 Pr.1: Unit setting = degree • -2000000000 to +2000000000 Pr.1: Unit setting = pulse • -1000000000 to +1000000000	Set the command speed at speed control mode.
Cd.141: Acceleration time at speed control mode	i_uSpeedAccelerationTime	Word [unsigned]	0 to 65535 (0 to 32767: Set by decimal number. 32768 to 65535: Convert the number to hexadecimal number and set.)	Set the acceleration time at speed control mode.
Cd.142: Deceleration time at speed control mode	i_uSpeedDecelerationTime	Word [unsigned]	0 to 65535 (0 to 32767: Set by decimal number. 32768 to 65535: Convert the number to hexadecimal number and set.)	Set the deceleration time at speed control mode.

Output labels

Name	Variable name	Data type	Default value	Description
Execution status	o_bENO	Bit	OFF	ON: The execution command is ON. OFF: The execution command is OFF.
Completed without error	o_bOK	Bit	OFF	When ON, it indicates that changing control mode has been completed.
Error flag	o_bErr	Bit	OFF	When ON, it indicates that an error has occurred in the FB.
Error code	o_uErrId	Word [unsigned]	0	The error code generated in the FB is stored.

Version upgrade history

Version	Date	Description
00D	2014/06/30	First edition

2.15 M+RD77_ChangePositionControlMode

Name

M+RD77_ChangePositionControlMode

Function overview

Item	Description	
Function overview	Activates the position control mode.	
Symbol		
Applicable hardware and software	Applicable module	RD77MS16, RD77MS8, RD77MS4, RD77MS2
	Applicable CPU	MELSEC iQ-R series
	Applicable engineering software	GX Works3
Programming language	Ladder	
Number of steps (maximum)	347 steps	
Function description	<ul style="list-style-type: none"> • By turning ON i_bEN (Execution command), the position control mode is activated for the specified axis. • When this FB is executed during position control, the execution is completed without any processing. • When the setting value of the target axis is out of the range, o_bErr (Error flag) turns ON, the FB processing is interrupted, and the error code 100 (Hexadecimal) is stored in o_uErrId (Error code). 	
Compiling method	Macro type	
FB operation type	Pulsed execution (multiple scan execution type)	

Item	Description
Timing chart	<p>When operation completes without an error</p> <p>When an error occurs</p>

Restrictions and precautions	<ul style="list-style-type: none"> • The FB does not include error recovery processing. Program the error recovery processing separately in accordance with the required system operation. • The FB cannot be used in an interrupt program. • Ensure that i_bEN (Execution command) is capable of being turned OFF by the program. Do not use this FB in programs that are only executed once such as a subroutine and FOR-NEXT loop because i_bEN (Execution command) cannot be turned OFF. • When this FB is used twice or more, precaution must be taken to avoid repetition of the target axis. • Every input must be provided with a value for proper FB operation. • When this FB fails switching the mode, o_bOK (Completed without error) does not turn ON.
------------------------------	---

Error codes

Error code	Description	Action
100 (Hexadecimal)	The setting value of i_uAxis (Target axis) is out of the range. The target axis is not within the range of 1 to 16.	Please try again after confirming the setting.

Labels

■Input labels

Name	Variable name	Data type	Setting range	Description
Execution command	i_bEN	Bit	ON, OFF	ON: The FB is activated. OFF: The FB is not activated.
Module label	i_stModule	Structure	The setting range differs depending on the module label.	Specify the module label of the MELSEC iQ-R simple motion module.
Target axis	i_uAxis	Word [unsigned]	1 to 16	Specify the axis number.

■Output labels

Name	Variable name	Data type	Default value	Description
Execution status	o_bENO	Bit	OFF	ON: The execution command is ON. OFF: The execution command is OFF.
Completed without error	o_bOK	Bit	OFF	When ON, it indicates that changing control mode has been completed.
Error flag	o_bErr	Bit	OFF	When ON, it indicates that an error has occurred in the FB.
Error code	o_uErrId	Word [unsigned]	0	The error code generated in the FB is stored.

Version upgrade history

Version	Date	Description
00D	2014/06/30	First edition

2.16 M+RD77_ChangeContinuousTorqueMode

Name

M+RD77_ChangeContinuousTorqueMode

Function overview

Item	Description	
Function overview	Activates the continuous operation to torque control mode.	
Symbol	<p>The diagram shows a central block titled 'M+RD77_ChangeContinuousTorqueMode'. On the left side, there are several inputs: 'Execution command' (B : i_bEN), 'Module label' (DUT : i_stModule), 'Target axis' (UW : i_uAxis), 'Cd.147: Speed limit value at continuous operation to torque control mode' (D : i_dSpeedLimit), 'Cd.148: Acceleration time at continuous operation to torque control mode' (UW : i_uSpeedAccelerationTime), 'Cd.149: Deceleration time at continuous operation to torque control mode' (UW : i_uSpeedDecelerationTime), 'Cd.150: Target torque at continuous operation to torque control mode' (W : i_wCommandTorque), 'Cd.151: Torque time constant at continuous operation to torque control mode (Forward direction)' (UW : i_uTorqueTimeConstDrivingMode), 'Cd.152: Torque time constant at continuous operation to torque control mode (Negative direction)' (UW : i_uTorqueTimeConstRegenerativeMode), 'Cd.153: Control mode auto-shift selection' (UW : i_uAutoSwitchingMode), and 'Cd.154: Control mode auto-shift parameter' (D : i_dAutoSwitchingParameter). On the right side, there are four outputs: 'Execution status' (o_bENO : B), 'Completed without error' (o_bOK : B), 'Error flag' (o_bErr : B), and 'Error code' (o_uErrId : UW).</p>	
Applicable hardware and software	Applicable module	RD77MS16, RD77MS8, RD77MS4, RD77MS2
	Applicable CPU	MELSEC iQ-R series
	Applicable engineering software	GX Works3
Programming language	Ladder	
Number of steps (maximum)	523 steps	
Function description	<ul style="list-style-type: none"> • By turning ON i_bEN (Execution command), the continuous operation to torque control mode is activated for the specified axis. • When this FB is executed during continuous operation to torque control mode, the speed limit value and target torque are changed. • When the setting value of the target axis is out of the range, o_bErr (Error flag) turns ON, the FB processing is interrupted, and the error code 100 (Hexadecimal) is stored in o_uErrId (Error code). 	
Compiling method	Macro type	
FB operation type	Pulsed execution (multiple scan execution type)	

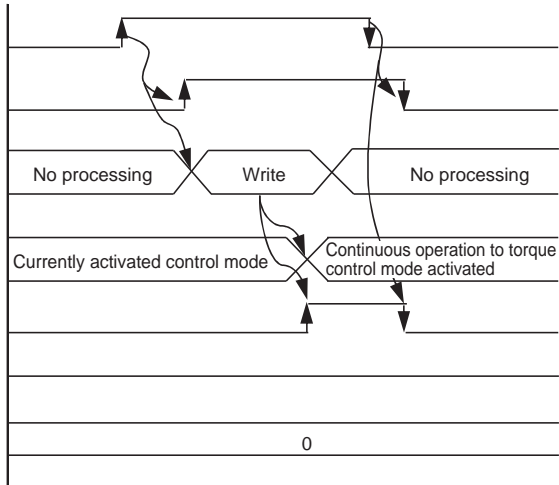
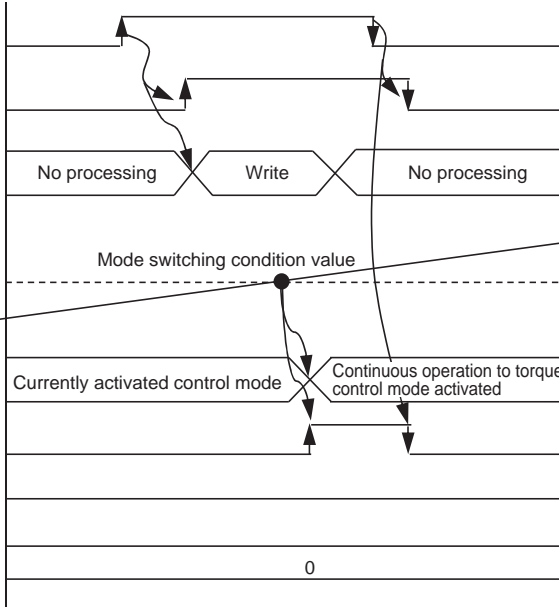
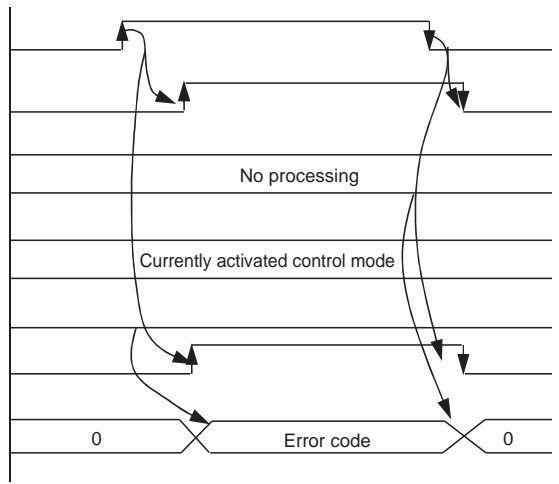
Item	Description
Timing chart	<p>When operation completes without an error</p> <ul style="list-style-type: none"> When the control mode auto-shift selection is set to 0  <ul style="list-style-type: none"> When the control mode auto-shift selection is set to other than 0  <p>When an error occurs</p> 

Item	Description
Restrictions and precautions	<ul style="list-style-type: none"> The FB does not include error recovery processing. Program the error recovery processing separately in accordance with the required system operation. The FB cannot be used in an interrupt program. Ensure that i_bEN (Execution command) is capable of being turned OFF by the program. Do not use this FB in programs that are only executed once such as a subroutine and FOR-NEXT loop because i_bEN (Execution command) cannot be turned OFF. When this FB is used twice or more, precaution must be taken to avoid repetition of the target axis. Every input must be provided with a value for proper FB operation. When this FB fails switching the mode, o_bOK (Completed without error) does not turn ON.

Error codes

Error code	Description	Action
100 (Hexadecimal)	The setting value of i_uAxis (Target axis) is out of the range. The target axis is not within the range of 1 to 16.	Please try again after confirming the setting.

Labels

Input labels

Name	Variable name	Data type	Setting range	Description
Execution command	i_bEN	Bit	ON, OFF	ON: The FB is activated. OFF: The FB is not activated.
Module label	i_stModule	Structure	The setting range differs depending on the module label.	Specify the module label of the MELSEC iQ-R simple motion module.
Target axis	i_uAxis	Word [unsigned]	1 to 16	Specify the axis number. The setting range differs depending on the module used.
Cd.147: Speed limit value at continuous operation to torque control mode	i_dSpeedLimit	Double word [signed]	Pr.1: Unit setting = mm • -2000000000 to +2000000000 Pr.1: Unit setting = inch • -2000000000 to +2000000000 Pr.1: Unit setting = degree • -2000000000 to +2000000000 Pr.1: Unit setting = pulse • -1000000000 to +1000000000	Set the speed limit value at continuous operation to torque control mode.
Cd.148: Acceleration time at continuous operation to torque control mode	i_uSpeedAccelerationTime	Word [unsigned]	0 to 65535 (0 to 32767: Set by decimal number. 32768 to 65535: Convert the number to hexadecimal number and set.)	Set the acceleration time at continuous operation to torque control mode.
Cd.149: Deceleration time at continuous operation to torque control mode	i_uSpeedDecelerationTime	Word [unsigned]	0 to 65535 (0 to 32767: Set by decimal number. 32768 to 65535: Convert the number to hexadecimal number and set.)	Set the deceleration time at continuous operation to torque control mode.
Cd.150: Target torque at continuous operation to torque control mode	i_wCommandTorque	Word [signed]	-10000 to 10000	Set the target torque at continuous operation to torque control mode.
Cd.151: Torque time constant at continuous operation to torque control mode (Forward direction)	i_uTorqueTimeConstDriving Mode	Word [unsigned]	0 to 65535 (0 to 32767: Set by decimal number. 32768 to 65535: Convert the number to hexadecimal number and set.)	Set the time constant for the driving at continuous operation to torque control mode.
Cd.152: Torque time constant at continuous operation to torque control mode (Negative direction)	i_uTorqueTimeConstRegenerativeMode	Word [unsigned]	0 to 65535 (0 to 32767: Set by decimal number. 32768 to 65535: Convert the number to hexadecimal number and set.)	Set the time constant for the regeneration at continuous operation to torque control mode.
Cd.153: Control mode auto-shift selection	i_uAutoSwitchingMode	Word [unsigned]	0 to 2	Set the switching condition of the control mode to switch to continuous operation to torque control mode.

Name	Variable name	Data type	Setting range	Description
Cd.154: Control mode auto-shift parameter	i_dAutoSwitchingParameter	Double word [signed]	Pr.1: Unit setting = mm <ul style="list-style-type: none"> -2147483648 to +2147483648 Pr.1: Unit setting = inch <ul style="list-style-type: none"> -2147483648 to +2147483648 Pr.1: Unit setting = degree <ul style="list-style-type: none"> 0 to 35999999 Pr.1: Unit setting = pulse <ul style="list-style-type: none"> -2147483648 to +2147483648 	Set the condition value when the control mode auto-shift selection is set to 1 or 2.

■Output labels

Name	Variable name	Data type	Default value	Description
Execution status	o_bENO	Bit	OFF	ON: The execution command is ON. OFF: The execution command is OFF.
Completed without error	o_bOK	Bit	OFF	When ON, it indicates that changing control mode has been completed.
Error flag	o_bErr	Bit	OFF	When ON, it indicates that an error has occurred in the FB.
Error code	o_uErrId	Word [unsigned]	0	The error code generated in the FB is stored.

Version upgrade history

Version	Date	Description
00D	2014/06/30	First edition

2.17 M+RD77_Sync

Name

M+RD77_Sync

Function overview

Item	Description	
Function overview	Starts and ends the synchronous control.	
Symbol	<pre> graph LR subgraph M+RD77_Sync direction TB i_bEN["B : i_bEN"] i_stModule["DUT : i_stModule"] i_uOutputAxis["UW : i_uOutputAxis"] o_bENO["o_bENO : B"] o_bOK["o_bOK : B"] o_bErr["o_bErr : B"] o_uErrId["o_uErrId : UW"] end i_bEN --- M+RD77_Sync i_stModule --- M+RD77_Sync i_uOutputAxis --- M+RD77_Sync M+RD77_Sync --- o_bENO M+RD77_Sync --- o_bOK M+RD77_Sync --- o_bErr M+RD77_Sync --- o_uErrId </pre>	
Applicable hardware and software	Applicable module	RD77MS16, RD77MS8, RD77MS4, RD77MS2
	Applicable CPU	MELSEC iQ-R series
	Applicable engineering software	GX Works3
Programming language	Ladder	
Number of steps (maximum)	178 steps	
Function description	<ul style="list-style-type: none"> By turning ON i_bEN (Execution command), synchronous control of the output axis No. is started. Turning OFF i_bEN (Execution command) ends the synchronous control. When the setting value of the output axis No. is out of the range, o_bErr (Error flag) turns ON, the FB processing is interrupted, and the error code 100 (Hexadecimal) is stored in o_uErrId (Error code). The synchronous control does not start while the READY signal (X0) is OFF, the BUSY signal (X10 to X1F) is ON, or the error detection signal is ON. 	
Compiling method	Macro type	
FB operation type	Pulsed execution (multiple scan execution type)	

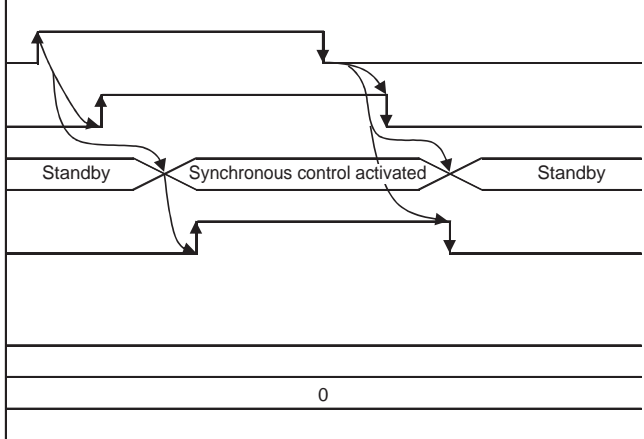
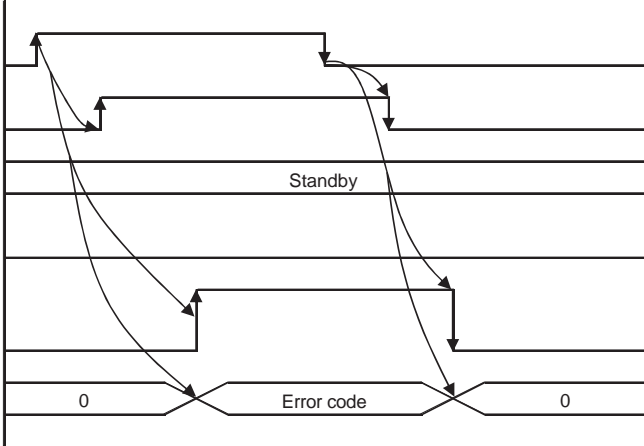
Item	Description
Timing chart	<p>When operation completes without an error</p>  <p>When an error occurs</p> 
Restrictions and precautions	<ul style="list-style-type: none"> • The FB does not include error recovery processing. Program the error recovery processing separately in accordance with the required system operation. • The FB cannot be used in an interrupt program. • When this FB is used twice or more, precaution must be taken to avoid repetition of the output axis No. • Every input must be provided with a value for proper FB operation.

Error codes

Error code	Description	Action
100 (Hexadecimal)	The output axis No. is not within the setting range.	Please try again after confirming the setting.

Labels

■Input labels

Name	Variable name	Data type	Setting range	Description
Execution command	i_bEN	Bit	ON, OFF	ON: The FB is activated. OFF: The FB is not activated.
Module label	i_stModule	Structure	The setting range differs depending on the module label.	Specify the module label of the MELSEC iQ-R simple motion module.
Output axis No.	i_uOutputAxis	Word [unsigned]	1 to 16	Specify the axis number for which synchronous control is started. The setting range differs depending on the module used.

■Output labels

Name	Variable name	Data type	Default value	Description
Execution status	o_bENO	Bit	OFF	ON: The execution command is ON. OFF: The execution command is OFF.
Completed without error	o_bOK	Bit	OFF	When ON, it indicates that synchronous control has been started.
Error flag	o_bErr	Bit	OFF	When ON, it indicates that an error has occurred in the FB.
Error code	o_uErrId	Word [unsigned]	0	The error code generated in the FB is stored.

Version upgrade history

Version	Date	Description
00D	2014/06/30	First edition

2.18 M+RD77_ChangeSyncEncoderPosition

Name

M+RD77_ChangeSyncEncoderPosition

Function overview

Item	Description	
Function overview	Changes the synchronous encoder axis current value and synchronous encoder axis current value per cycle.	
Symbol		
Applicable hardware and software	Applicable module	RD77MS16, RD77MS8, RD77MS4, RD77MS2
	Applicable CPU	MELSEC iQ-R series
	Applicable engineering software	GX Works3
Programming language	Ladder	
Number of steps (maximum)	215 steps	
Function description	<ul style="list-style-type: none"> The operation method differs depending on the setting value of the synchronous encoder axis control start. When the setting value is 1, the synchronous encoder axis current value is changed by turning ON i_bEN (Execution command). When the setting value is 101 to 116, the synchronous encoder axis current value is changed by the high speed input request [DI] after i_bEN (Execution command) is turned ON. When the setting value of the synchronous encoder axis No. is out of the range, o_bErr (Error flag) turns ON, the FB processing is interrupted, and the error code 100 (Hexadecimal) is stored in o_uErrId (Error code). When this FB is executed for the synchronous encoder axis for which the synchronous encoder axis enabled flag is OFF, o_bErr (Error flag) turns ON, the FB processing is interrupted, and the error code 301 (Hexadecimal) is stored in o_uErrId (Error code). 	
Compiling method	Macro type	
FB operation type	Pulsed execution (single scan execution type)	

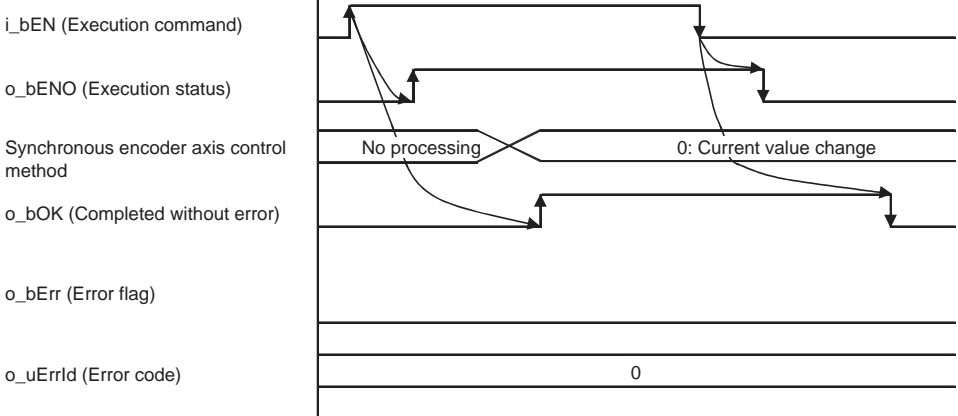
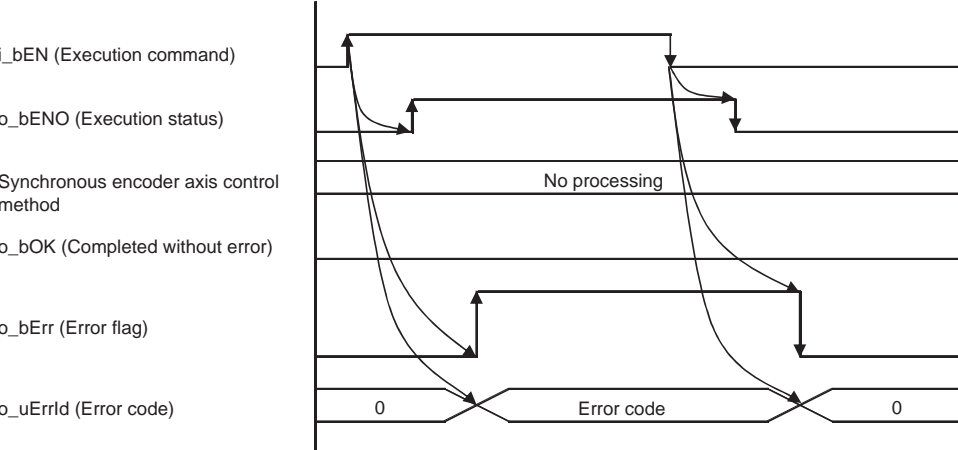
Item	Description
Timing chart	<p>When operation completes without an error</p>  <p>When an error occurs</p> 
Restrictions and precautions	<ul style="list-style-type: none"> • The FB does not include error recovery processing. Program the error recovery processing separately in accordance with the required system operation. • The FB cannot be used in an interrupt program. • When this FB is used twice or more, precaution must be taken to avoid repetition of the synchronous encoder axis No. • Every input must be provided with a value for proper FB operation.

Error codes

Error code	Description	Action
100 (Hexadecimal)	The synchronous encoder axis No. is not within the setting range.	Please try again after confirming the setting.
301 (Hexadecimal)	The synchronous encoder axis enabled flag of the synchronous encoder axis No. is OFF.	Please try again after confirming the setting.

Labels

■ Input labels

Name	Variable name	Data type	Setting range	Description
Execution command	i_bEN	Bit	ON, OFF	ON: The FB is activated. OFF: The FB is not activated.
Module label	i_stModule	Structure	The setting range differs depending on the module label.	Specify the module label of the MELSEC iQ-R simple motion module.
Synchronous encoder axis No.	i_uSyncEncAxis	Word [unsigned]	1 to 4: Synchronous encoder axis number	Set the synchronous encoder axis number whose current value is to be changed.
Cd.320: Synchronous encoder axis control start	i_uStartControl	Word [unsigned]	1: Start for synchronous encoder axis control 101 to 116: High-speed input start for synchronous encoder axis control (axis 1 to axis 16)	When 1 is set, synchronous encoder axis control is started. When 101 to 116 is set, the synchronous encoder axis control starts based on the high-speed input request (external command signal). The setting range differs depending on the module used.
Cd.322: Synchronous encoder axis current value setting address	i_dNewPosition	Double word [signed]	Pr.321: Unit setting = mm • -2147483648 to 2147483647 Pr.321: Unit setting = inch • -2147483648 to 2147483647 Pr.321: Unit setting = degree • -2147483648 to 2147483647 Pr.321: Unit setting = pulse • -2147483648 to 2147483647	Set the new current value after a current value change.

■ Output labels

Name	Variable name	Data type	Default value	Description
Execution status	o_bENO	Bit	OFF	ON: The execution command is ON. OFF: The execution command is OFF.
Completed without error	o_bOK	Bit	OFF	When ON, it indicates that setting the synchronous encoder axis current value change has been completed.
Error flag	o_bErr	Bit	OFF	When ON, it indicates that an error has occurred in the FB.
Error code	o_uErrId	Word [unsigned]	0	The error code generated in the FB is stored.

Version upgrade history

Version	Date	Description
00D	2014/06/30	First edition

2.19 M+RD77_DisableSyncEncoder

Name

M+RD77_DisableSyncEncoder

Function overview

Item	Description	
Function overview	Disables inputs from the synchronous encoder axis.	
Symbol	<p>The diagram shows a central block labeled 'M+RD77_DisableSyncEncoder'. On the left side, there are four inputs: 'Execution command' (B : i_bEN), 'Module label' (DUT : i_stModule), 'Synchronous encoder axis No.' (UW : i_uSyncEncAxis), and 'Cd.320: Synchronous encoder axis control start' (UW : i_uStartControl). On the right side, there are four outputs: 'o_bENO : B' (Execution status), 'o_bOK : B' (Completed without error), 'o_bErr : B' (Error flag), and 'o_uErrId : UW' (Error code).</p>	
Applicable hardware and software	Applicable module	RD77MS16, RD77MS8, RD77MS4, RD77MS2
	Applicable CPU	MELSEC iQ-R series
	Applicable engineering software	GX Works3
Programming language	Ladder	
Number of steps (maximum)	170 steps	
Function description	<ul style="list-style-type: none"> The operation method differs depending on the setting value of the synchronous encoder axis control start. When the setting value is 1, the synchronous encoder axis counter is disabled by turning ON i_bEN (Execution command). When the setting value is 101 to 116, the synchronous encoder axis counter is disabled by the high speed input request [DI] after i_bEN (Execution command) is turned ON. When the setting value of the synchronous encoder axis No. is out of the range, o_bErr (Error flag) turns ON, the FB processing is interrupted, and the error code 100 (Hexadecimal) is stored in o_uErrId (Error code). When this FB is executed for the synchronous encoder axis for which the synchronous encoder axis enabled flag is OFF, o_bErr (Error flag) turns ON, the FB processing is interrupted, and the error code 301 (Hexadecimal) is stored in o_uErrId (Error code). 	
Compiling method	Macro type	
FB operation type	Pulsed execution (single scan execution type)	

Item	Description
Timing chart	<p>When operation completes without an error</p> <p>When an error occurs</p> <p>Restrictions and precautions</p> <ul style="list-style-type: none"> • The FB does not include error recovery processing. Program the error recovery processing separately in accordance with the required system operation. • The FB cannot be used in an interrupt program. • When this FB is used twice or more, precaution must be taken to avoid repetition of the synchronous encoder axis No. • Every input must be provided with a value for proper FB operation.

Error codes

Error code	Description	Action
100 (Hexadecimal)	The synchronous encoder axis No. is not within the setting range.	Please try again after confirming the setting.
301 (Hexadecimal)	The synchronous encoder axis enabled flag of the synchronous encoder axis No. is OFF.	Execute the FB again after turning ON the synchronous encoder axis setting enabled flag.

Labels

■Input labels

Name	Variable name	Data type	Setting range	Description
Execution command	i_bEN	Bit	ON, OFF	ON: The FB is activated. OFF: The FB is not activated.
Module label	i_stModule	Structure	The setting range differs depending on the module label.	Specify the module label of the MELSEC iQ-R simple motion module.
Synchronous encoder axis No.	i_uSyncEncAxis	Word [unsigned]	1 to 4: Synchronous encoder axis number	Set the synchronous encoder axis number whose inputs are to be disabled.
Cd.320: Synchronous encoder axis control start	i_uStartControl	Word [unsigned]	1: Start for synchronous encoder axis control 101 to 116: High-speed input start for synchronous encoder axis control (axis 1 to axis 16)	When 1 is set, synchronous encoder axis control is started. When 101 to 116 is set, the synchronous encoder axis control starts based on the high-speed input request (external command signal). The setting range differs depending on the module used.

■Output labels

Name	Variable name	Data type	Default value	Description
Execution status	o_bENO	Bit	OFF	ON: The execution command is ON. OFF: The execution command is OFF.
Completed without error	o_bOK	Bit	OFF	When ON, it indicates that disabling the synchronous encoder axis counter has been completed.
Error flag	o_bErr	Bit	OFF	When ON, it indicates that an error has occurred in the FB.
Error code	o_uErrId	Word [unsigned]	0	The error code generated in the FB is stored.

Version upgrade history

Version	Date	Description
00D	2014/06/30	First edition

2.20 M+RD77_EnableSyncEncoder

Name

M+RD77_EnableSyncEncoder

Function overview

Item	Description	
Function overview	Enables inputs from the synchronous encoder axis.	
Symbol		
Applicable hardware and software	Applicable module	RD77MS16, RD77MS8, RD77MS4, RD77MS2
	Applicable CPU	MELSEC iQ-R series
	Applicable engineering software	GX Works3
Programming language	Ladder	
Number of steps (maximum)	170 steps	
Function description	<ul style="list-style-type: none"> The operation method differs depending on the setting value of the synchronous encoder axis control start. When the setting value is 1, the synchronous encoder axis counter is enabled by turning ON i_bEN (Execution command). When the setting value is 101 to 116, the synchronous encoder axis counter is enabled by the high speed input request [DI] after i_bEN (Execution command) is turned ON. When the setting value of the synchronous encoder axis No. is out of the range, o_bErr (Error flag) turns ON, the FB processing is interrupted, and the error code 100 (Hexadecimal) is stored in o_uErrId (Error code). When this FB is executed for the synchronous encoder axis for which the synchronous encoder axis enabled flag is OFF, o_bErr (Error flag) turns ON, the FB processing is interrupted, and the error code 301 (Hexadecimal) is stored in o_uErrId (Error code). 	
Compiling method	Macro type	
FB operation type	Pulsed execution (single scan execution type)	

Item	Description
Timing chart	<p>When operation completes without an error</p> <p>When an error occurs</p>
Restrictions and precautions	<ul style="list-style-type: none"> • The FB does not include error recovery processing. Program the error recovery processing separately in accordance with the required system operation. • The FB cannot be used in an interrupt program. • When this FB is used twice or more, precaution must be taken to avoid repetition of the synchronous encoder axis No. • Every input must be provided with a value for proper FB operation.

Error codes

Error code	Description	Action
100 (Hexadecimal)	The synchronous encoder axis No. is not within the setting range.	Please try again after confirming the setting.
301 (Hexadecimal)	The synchronous encoder axis enabled flag of the synchronous encoder axis No. is OFF.	Execute the FB again after turning ON the synchronous encoder axis setting enabled flag.

Labels

■Input labels

Name	Variable name	Data type	Setting range	Description
Execution command	i_bEN	Bit	ON, OFF	ON: The FB is activated. OFF: The FB is not activated.
Module label	i_stModule	Structure	The setting range differs depending on the module label.	Specify the module label of the MELSEC iQ-R simple motion module.
Synchronous encoder axis No.	i_uSyncEncAxis	Word [unsigned]	1 to 4: Synchronous encoder axis number	Set the synchronous encoder axis number whose inputs are to be enabled.
Cd.320: Synchronous encoder axis control start	i_uStartControl	Word [unsigned]	1: Start for synchronous encoder axis control 101 to 116: High-speed input start for synchronous encoder axis control (axis 1 to axis 16)	When 1 is set, synchronous encoder axis control is started. When 101 to 116 is set, the synchronous encoder axis control starts based on the high-speed input request (external command signal). The setting range differs depending on the module used.

■Output labels

Name	Variable name	Data type	Default value	Description
Execution status	o_bENO	Bit	OFF	ON: The execution command is ON. OFF: The execution command is OFF.
Completed without error	o_bOK	Bit	OFF	When ON, it indicates that enabling the synchronous encoder axis counter has been completed.
Error flag	o_bErr	Bit	OFF	When ON, it indicates that an error has occurred in the FB.
Error code	o_uErrId	Word [unsigned]	0	The error code generated in the FB is stored.

Version upgrade history

Version	Date	Description
00D	2014/06/30	First edition

2.21 M+RD77_ResetSyncEncoderError

Name

M+RD77_ResetSyncEncoderError

Function overview

Item	Description	
Function overview	Reads error information from the synchronous encoder axis, and resets the error.	
Symbol	<p>The diagram shows a central block labeled 'M+RD77_ResetSyncEncoderError'. On the left side, there are four input lines: 'B : i_bEN' (Execution command), 'DUT : i_stModule' (Module label), 'UW : i_uSyncEncAxis' (Synchronous encoder axis No.), and 'B : i_bResetError' (Error reset request). On the right side, there are seven output lines: 'B : o_bENO' (Execution status), 'B : o_bOK' (Completed without error), 'B : o_bModuleErr' (Error detection), 'UW : o_uErrorNo' (Error No.), 'B : o_bModuleWarn' (Warning detection), 'UW : o_uWarningNo' (Warning No.), and 'B : o_bErr' (Error flag). Below these, 'UW : o_uErrId' (Error code) is also listed as an output.</p>	
Applicable hardware and software	Applicable module	RD77MS16, RD77MS8, RD77MS4, RD77MS2
	Applicable CPU	MELSEC iQ-R series
	Applicable engineering software	GX Works3
Programming language	Ladder	
Number of steps (maximum)	360 steps	
Function description	<ul style="list-style-type: none"> • By turn ON i_bEN (Execution command), the synchronous encoder axis error and warning information of the synchronous encoder axis No. are read. • When the error reset request is ON, the error and warning are reset. • When the setting value of the synchronous encoder axis No. is out of the range, o_bErr (Error flag) turns ON, the FB processing is interrupted, and the error code 100 (Hexadecimal) is stored in o_uErrId (Error code). 	
Compiling method	Macro type	
FB operation type	Real-time execution	

Item	Description
Timing chart	<p>When operation completes without an error (error reset)</p> <p>When operation completes without an error (warning reset)</p>

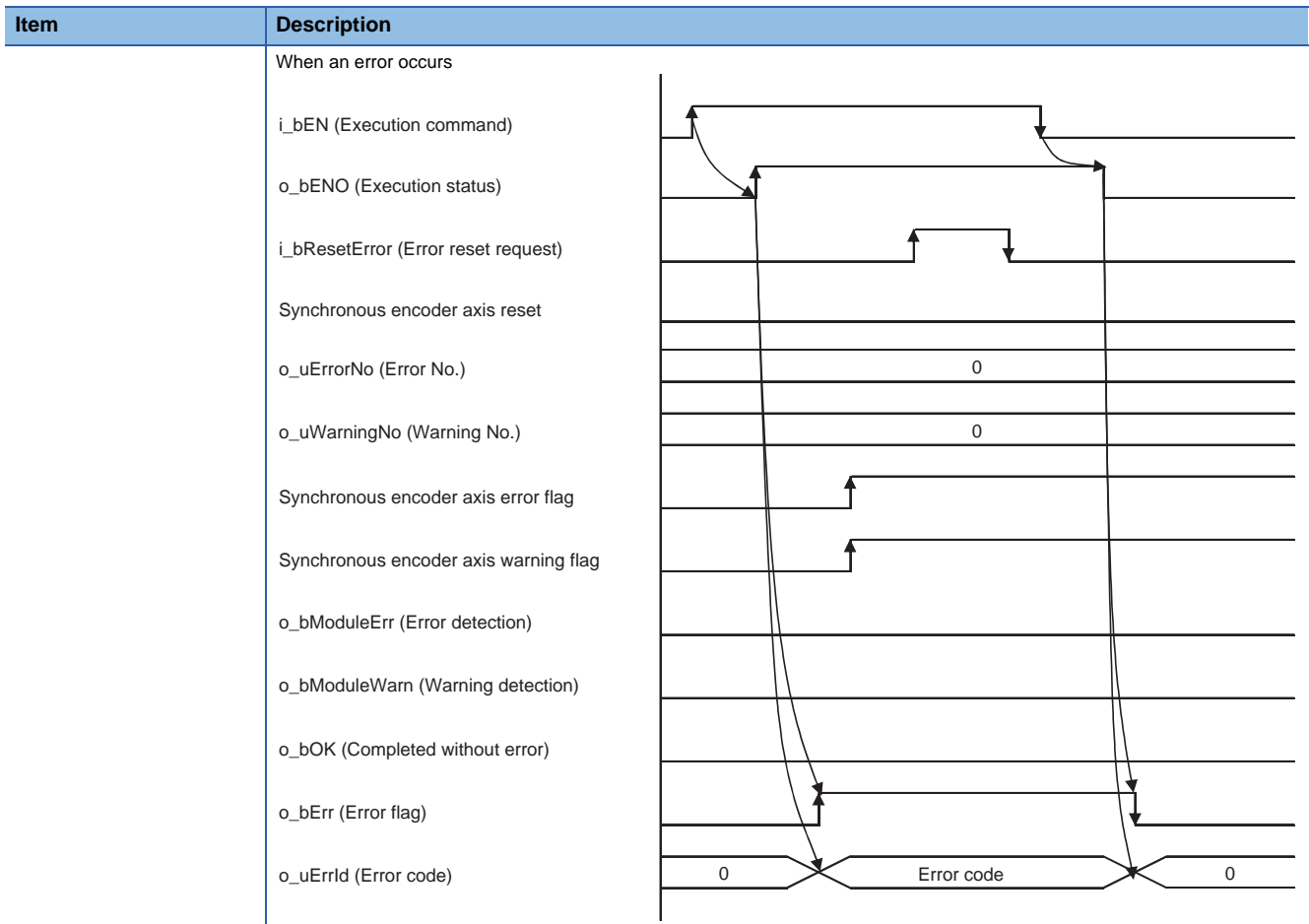

Restrictions and precautions

- The FB does not include error recovery processing. Program the error recovery processing separately in accordance with the required system operation.
- The FB cannot be used in an interrupt program.
- When this FB is used twice or more, precaution must be taken to avoid repetition of the synchronous encoder axis No.
- Every input must be provided with a value for proper FB operation.

Error codes

Error code	Description	Action
100 (Hexadecimal)	The synchronous encoder axis No. is not within the setting range.	Please try again after confirming the setting.

Labels

Input labels

Name	Variable name	Data type	Setting range	Description
Execution command	i_bEN	Bit	ON, OFF	ON: The FB is activated. OFF: The FB is not activated.
Module label	i_stModule	Structure	The setting range differs depending on the module label.	Specify the module label of the MELSEC iQ-R simple motion module.
Synchronous encoder axis No.	i_uSyncEncAxis	Word [unsigned]	1 to 4	Set the synchronous encoder axis number from which the error No. and warning No. are read.
Error reset request	i_bResetError	Bit	ON, OFF	Turn ON this label to reset errors. Turn OFF this label after the error reset is completed.

■ Output labels

Name	Variable name	Data type	Default value	Description
Execution status	o_bENO	Bit	OFF	ON: The execution command is ON. OFF: The execution command is OFF.
Completed without error	o_bOK	Bit	OFF	When ON, it indicates that the error detection flag and warning detection flag of the synchronous encoder axis status have been turned OFF.
Error detection	o_bModuleErr	Bit	OFF	When ON, it indicates that the synchronous encoder axis error has occurred.
Error No.	o_uErrorNo	Word [unsigned]	0	When the synchronous encoder axis error is detected, the error code corresponding to the error is stored.
Warning detection	o_bModuleWarn	Bit	OFF	When ON, it indicates that the synchronous encoder axis warning has occurred.
Warning No.	o_uWarningNo	Word [unsigned]	0	When the synchronous encoder axis warning is detected, the warning code corresponding to the warning is stored.
Error flag	o_bErr	Bit	OFF	When ON, it indicates that an error has occurred in the FB.
Error code	o_uErrId	Word [unsigned]	0	The error code generated in the FB is stored.

Version upgrade history

Version	Date	Description
00D	2014/06/30	First edition

2.22 M+RD77_ConnectSyncEncoder

Name

M+RD77_ConnectSyncEncoder

Function overview

Item	Description	
Function overview	Connects a synchronous encoder via CPU.	
Symbol	<p>The diagram shows a rectangular block labeled 'M+RD77_ConnectSyncEncoder'. On the left side, there are three input lines: 'B : i_bEN' (Execution command), 'DUT : i_stModule' (Module label), and 'UW : i_uSyncEncAxis' (Synchronous encoder axis No.). On the right side, there are four output lines: 'o_bENO : B' (Execution status), 'o_bOK : B' (Completed without error), 'o_bErr : B' (Error flag), and 'o_uErrId : UW' (Error code).</p>	
Applicable hardware and software	Applicable module	RD77MS16, RD77MS8, RD77MS4, RD77MS2
	Applicable CPU	MELSEC iQ-R series
	Applicable engineering software	GX Works3
Programming language	Ladder	
Number of steps (maximum)	176 steps	
Function description	<ul style="list-style-type: none"> • By turning ON i_bEN (Execution command), the synchronous encoder of the synchronous encoder axis No. is connected via CPU. • When the setting value of the synchronous encoder axis No. is out of the range, o_bErr (Error flag) turns ON, the FB processing is interrupted, and the error code 100 (Hexadecimal) is stored in o_uErrId (Error code). • When this FB is executed for the synchronous encoder axis for which the synchronous encoder axis enabled flag is OFF, o_bErr (Error flag) turns ON, the FB processing is interrupted, and the error code 301 (Hexadecimal) is stored in o_uErrId (Error code). 	
Compiling method	Macro type	
FB operation type	Pulsed execution (multiple scan execution type)	

Item	Description
Timing chart	<p>When operation completes without an error</p> <p>When an error occurs</p>
Restrictions and precautions	<ul style="list-style-type: none"> • The FB does not include error recovery processing. Program the error recovery processing separately in accordance with the required system operation. • The FB cannot be used in an interrupt program. • When this FB is used twice or more, precaution must be taken to avoid repetition of the synchronous encoder axis No. • Every input must be provided with a value for proper FB operation.

Error codes

Error code	Description	Action
100 (Hexadecimal)	The synchronous encoder axis No. is not within the setting range.	Please try again after confirming the setting.
301 (Hexadecimal)	The synchronous encoder axis enabled flag of the synchronous encoder axis No. is OFF.	Execute the FB again after turning ON the synchronous encoder axis setting enabled flag.

Labels

■Input labels

Name	Variable name	Data type	Setting range	Description
Execution command	i_bEN	Bit	ON, OFF	ON: The FB is activated. OFF: The FB is not activated.
Module label	i_stModule	Structure	The setting range differs depending on the module label.	Specify the module label of the MELSEC iQ-R simple motion module.
Synchronous encoder axis No.	i_uSyncEncAxis	Word [unsigned]	1 to 4	Set the synchronous encoder axis number for which the connection command of the synchronous encoder via CPU is executed.

■Output labels

Name	Variable name	Data type	Default value	Description
Execution status	o_bENO	Bit	OFF	ON: The execution command is ON. OFF: The execution command is OFF.
Completed without error	o_bOK	Bit	OFF	When ON, it indicates that the connecting valid flag of the synchronous encoder axis status has been turned ON.
Error flag	o_bErr	Bit	OFF	When ON, it indicates that an error has occurred in the FB.
Error code	o_uErr_Id	Word [unsigned]	0	The error code generated in the FB is stored.

Version upgrade history

Version	Date	Description
00D	2014/06/30	First edition

2.23 M+RD77_MoveCamReferencePosition

Name

M+RD77_MoveCamReferencePosition

Function overview

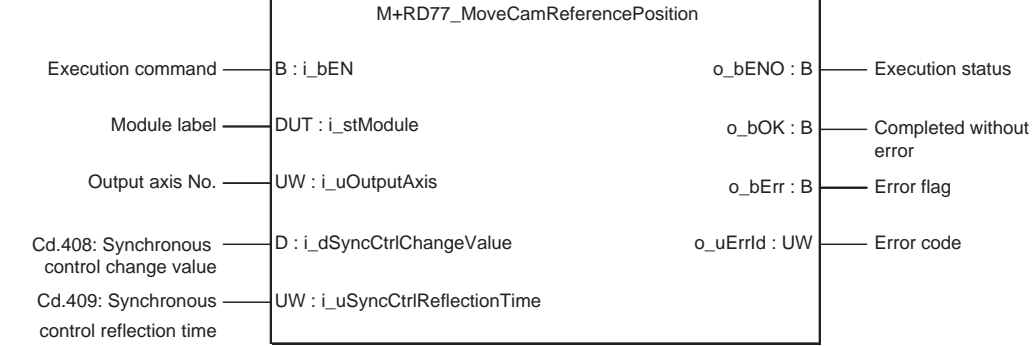
Item	Description	
Function overview	Adds the movement amount set in the synchronous control change value to the cam reference position to move the cam reference position.	
Symbol		
Applicable hardware and software	Applicable module	RD77MS16, RD77MS8, RD77MS4, RD77MS2
	Applicable CPU	MELSEC iQ-R series
	Applicable engineering software	GX Works3
Programming language	Ladder	
Number of steps (maximum)	355 steps	
Function description	<ul style="list-style-type: none"> • By turning ON i_bEN (Execution command), the cam reference position of the output axis No. is moved. • If i_bEN (Execution command) is turned OFF during movement of the cam reference position, the operation stops during the movement and o_bOK (Completed without error) does not turn ON. • When the setting value of the output axis No. is out of the range, o_bErr (Error flag) turns ON, the FB processing is interrupted, and the error code 100 (Hexadecimal) is stored in o_uErrId (Error code). • When this FB is executed for the output axis No. with which synchronous control is not executed, o_bErr (Error flag) turns ON, the FB processing is interrupted, and the error code 300 (Hexadecimal) is stored in o_uErrId (Error code). 	
Compiling method	Macro type	
FB operation type	Pulsed execution (multiple scan execution type)	

Item	Description
Timing chart	<p>When operation completes without an error</p> <p>When an error occurs</p>
Restrictions and precautions	<ul style="list-style-type: none"> • The FB does not include error recovery processing. Program the error recovery processing separately in accordance with the required system operation. • The FB cannot be used in an interrupt program. • When this FB is used twice or more, precaution must be taken to avoid repetition of the output axis No. • If this FB is used together with other synchronous control change FBs that have the same output axis No., secure one operation cycle or more after o_bOK (Completed without error) of this FB turns ON and before the FBs are executed. • Every input must be provided with a value for proper FB operation.

Error codes

Error code	Description	Action
100 (Hexadecimal)	The output axis No. is not within the setting range.	Please try again after confirming the setting.
300 (Hexadecimal)	The FB is executed for the output axis No. with which synchronous control is not executed.	Please try again after confirming the setting.

Labels

■Input labels

Name	Variable name	Data type	Setting range	Description
Execution command	i_bEN	Bit	ON, OFF	ON: The FB is activated. OFF: The FB is not activated.
Module label	i_stModule	Structure	The setting range differs depending on the module label.	Specify the module label of the MELSEC iQ-R simple motion module.
Output axis No.	i_uOutputAxis	Word [unsigned]	1 to 16	Set the axis number whose cam reference position is to be moved. The setting range differs depending on the module used.
Cd.408: Synchronous control change value	i_dSyncCtrlChangeValue	Double word [signed]	-2147483648 to 2147483647	Set the amount of the cam reference position movement.
Cd.409: Synchronous control reflection time	i_uSyncCtrlReflectionTime	Word [unsigned]	0 to 65535 (ms) (0 to 32767: Set by decimal number. 32768 to 65535: Convert the number to hexadecimal number and set.)	Set the reflection time for the synchronous control change.

■Output labels

Name	Variable name	Data type	Default value	Description
Execution status	o_bENO	Bit	OFF	ON: The execution command is ON. OFF: The execution command is OFF.
Completed without error	o_bOK	Bit	OFF	When ON, it indicates that moving the cam reference position has been completed.
Error flag	o_bErr	Bit	OFF	When ON, it indicates that an error has occurred in the FB.
Error code	o_uErr_Id	Word [unsigned]	0	The error code generated in the FB is stored.

Version upgrade history

Version	Date	Description
00D	2014/06/30	First edition

2.24 M+RD77_ChangeCamPositionPerCycle

Name

M+RD77_ChangeCamPositionPerCycle

Function overview

Item	Description	
Function overview	Changes the cam axis current value per cycle to a synchronous control change value.	
Symbol		
Applicable hardware and software	Applicable module	RD77MS16, RD77MS8, RD77MS4, RD77MS2
	Applicable CPU	MELSEC iQ-R series
	Applicable engineering software	GX Works3
Programming language	Ladder	
Number of steps (maximum)	213 steps	
Function description	<ul style="list-style-type: none"> • By turning ON i_bEN (Execution command), the cam axis current value per cycle of the output axis No. is changed. • When the setting value of the output axis No. is out of the range, o_bErr (Error flag) turns ON, the FB processing is interrupted, and the error code 100 (Hexadecimal) is stored in o_uErrId (Error code). • When this FB is executed for the output axis No. with which synchronous control is not executed, o_bErr (Error flag) turns ON, the FB processing is interrupted, and the error code 300 (Hexadecimal) is stored in o_uErrId (Error code). 	
Compiling method	Macro type	
FB operation type	Pulsed execution (multiple scan execution type)	

Item	Description
Timing chart	<p>When operation completes without an error</p> <p>When an error occurs</p>
Restrictions and precautions	<ul style="list-style-type: none"> • The FB does not include error recovery processing. Program the error recovery processing separately in accordance with the required system operation. • The FB cannot be used in an interrupt program. • When this FB is used twice or more, precaution must be taken to avoid repetition of the output axis No. • If this FB is used together with other synchronous control change FBs that have the same output axis No., secure one operation cycle or more after o_bOK (Completed without error) of this FB turns ON and before the FBs are executed. • Every input must be provided with a value for proper FB operation.

Error codes

Error code	Description	Action
100 (Hexadecimal)	The output axis No. is not within the setting range.	Please try again after confirming the setting.
300 (Hexadecimal)	The FB is executed for the output axis No. with which synchronous control is not executed.	Please try again after confirming the setting.

Labels

■Input labels

Name	Variable name	Data type	Setting range	Description
Execution command	i_bEN	Bit	ON, OFF	ON: The FB is activated. OFF: The FB is not activated.
Module label	i_stModule	Structure	The setting range differs depending on the module label.	Specify the module label of the MELSEC iQ-R simple motion module.
Output axis No.	i_uOutputAxis	Word [unsigned]	1 to 16	Set the axis number whose cam axis current value per cycle is to be changed. The setting range differs depending on the module used.
Cd.408: Synchronous control change value	i_dSyncCtrlChange Value	Double word [signed]	-2147483648 to 2147483647	Set the cam axis current value per cycle to be changed. The setting value is converted within the range from 0 to (Cam axis length per cycle - 1).

■Output labels

Name	Variable name	Data type	Default value	Description
Execution status	o_bENO	Bit	OFF	ON: The execution command is ON. OFF: The execution command is OFF.
Completed without error	o_bOK	Bit	OFF	When ON, it indicates that changing the cam axis current value per cycle has been completed.
Error flag	o_bErr	Bit	OFF	When ON, it indicates that an error has occurred in the FB.
Error code	o_uErr_Id	Word [unsigned]	0	The error code generated in the FB is stored.

Version upgrade history

Version	Date	Description
00D	2014/06/30	First edition

2.25 M+RD77_ChangeMainShaftGearPositionPerCycle

Name

M+RD77_ChangeMainShaftGearPositionPerCycle

Function overview

Item	Description	
Function overview	Changes the current value per cycle after main shaft gear to a synchronous control change value.	
Symbol	<div style="text-align: center;"> </div>	
Applicable hardware and software	Applicable module	RD77MS16, RD77MS8, RD77MS4, RD77MS2
	Applicable CPU	MELSEC iQ-R series
	Applicable engineering software	GX Works3
Programming language	Ladder	
Number of steps (maximum)	213 steps	
Function description	<ul style="list-style-type: none"> • By turning ON i_bEN (Execution command), the current value per cycle after main shaft gear of the output axis No. is changed. • When the setting value of the output axis No. is out of the range, o_bErr (Error flag) turns ON, the FB processing is interrupted, and the error code 100 (Hexadecimal) is stored in o_uErrld (Error code). • When this FB is executed for the output axis No. with which synchronous control is not executed, o_bErr (Error flag) turns ON, the FB processing is interrupted, and the error code 300 (Hexadecimal) is stored in o_uErrld (Error code). 	
Compiling method	Macro type	
FB operation type	Pulsed execution (multiple scan execution type)	

Item	Description
Timing chart	<p>When operation completes without an error</p> <p>When an error occurs</p>

Restrictions and precautions	<ul style="list-style-type: none"> • The FB does not include error recovery processing. Program the error recovery processing separately in accordance with the required system operation. • The FB cannot be used in an interrupt program. • When this FB is used twice or more, precaution must be taken to avoid repetition of the output axis No. • If this FB is used together with other synchronous control change FBs that have the same output axis No., secure one operation cycle or more after o_bOK (Completed without error) of this FB turns ON and before the FBs are executed. • Every input must be provided with a value for proper FB operation.
------------------------------	---

Error codes

Error code	Description	Action
100 (Hexadecimal)	The output axis No. is not within the setting range.	Please try again after confirming the setting.
300 (Hexadecimal)	The FB is executed for the output axis No. with which synchronous control is not executed.	Please try again after confirming the setting.

Labels

■ Input labels

Name	Variable name	Data type	Setting range	Description
Execution command	i_bEN	Bit	ON, OFF	ON: The FB is activated. OFF: The FB is not activated.
Module label	i_stModule	Structure	The setting range differs depending on the module label.	Specify the module label of the MELSEC iQ-R simple motion module.
Output axis No.	i_uOutputAxis	Word [unsigned]	1 to 16	Set the axis whose current value per cycle after main shaft gear is to be changed. The setting range differs depending on the module used.
Cd.408: Synchronous control change value	i_dSyncCtrlChangeValue	Double word [signed]	-2147483648 to 2147483647	Set the current value per cycle after main shaft gear to be changed. The setting value is converted within the range from 0 to (Cam axis length per cycle - 1).

■ Output labels

Name	Variable name	Data type	Default value	Description
Execution status	o_bENO	Bit	OFF	ON: The execution command is ON. OFF: The execution command is OFF.
Completed without error	o_bOK	Bit	OFF	When ON, it indicates that changing the current value per cycle after main shaft gear has been completed.
Error flag	o_bErr	Bit	OFF	When ON, it indicates that an error has occurred in the FB.
Error code	o_uErr_Id	Word [unsigned]	0	The error code generated in the FB is stored.

Version upgrade history

Version	Date	Description
00D	2014/06/30	First edition

2.26 M+RD77_ChangeAuxiliaryShaftGearPositionPerCycle

Name

M+RD77_ChangeAuxiliaryShaftGearPositionPerCycle

Function overview

Item	Description	
Function overview	Changes the current value per cycle after auxiliary shaft gear to a synchronous control change value.	
Symbol	<div style="text-align: center;"> <pre> graph LR subgraph Block [M+RD77_ChangeAuxiliaryShaftGearPositionPerCycle] direction TB B["B : i_bEN"] DUT["DUT : i_stModule"] UW["UW : i_uOutputAxis"] D["D : i_dSyncCtrlChangeValue"] B --- DUT --- UW --- D end B --- B_OUT["o_bENO : B"] DUT --- DUT_OUT["o_bOK : B"] UW --- UW_OUT["o_bErr : B"] D --- D_OUT["o_uErrId : UW"] </pre> <p>The diagram shows a central function block with four inputs on the left and four outputs on the right. The inputs are: Execution command (B : i_bEN), Module label (DUT : i_stModule), Output axis No. (UW : i_uOutputAxis), and Cd.408: Synchronous control change value (D : i_dSyncCtrlChangeValue). The outputs are: Execution status (o_bENO : B), Completed without error (o_bOK : B), Error flag (o_bErr : B), and Error code (o_uErrId : UW).</p> </div>	
Applicable hardware and software	Applicable module	RD77MS16, RD77MS8, RD77MS4, RD77MS2
	Applicable CPU	MELSEC iQ-R series
	Applicable engineering software	GX Works3
Programming language	Ladder	
Number of steps (maximum)	213 steps	
Function description	<ul style="list-style-type: none"> By turning ON i_bEN (Execution command), the current value per cycle after auxiliary shaft gear of the output axis No. is changed. When the setting value of the output axis No. is out of the range, o_bErr (Error flag) turns ON, the FB processing is interrupted, and the error code 100 (Hexadecimal) is stored in o_uErrId (Error code). When this FB is executed for the output axis No. with which synchronous control is not executed, o_bErr (Error flag) turns ON, the FB processing is interrupted, and the error code 300 (Hexadecimal) is stored in o_uErrId (Error code). 	
Compiling method	Macro type	
FB operation type	Pulsed execution (multiple scan execution type)	

Item	Description
Timing chart	<p>When operation completes without an error</p> <p>When an error occurs</p> <p>Restrictions and precautions</p> <ul style="list-style-type: none"> • The FB does not include error recovery processing. Program the error recovery processing separately in accordance with the required system operation. • The FB cannot be used in an interrupt program. • When this FB is used twice or more, precaution must be taken to avoid repetition of the output axis No. • If this FB is used together with other synchronous control change FBs that have the same output axis No., secure one operation cycle or more after o_bOK (Completed without error) of this FB turns ON and before the FBs are executed. • Every input must be provided with a value for proper FB operation.

Error codes		
Error code	Description	Action
100 (Hexadecimal)	The output axis No. is not within the setting range.	Please try again after confirming the setting.
300 (Hexadecimal)	The FB is executed for the output axis No. with which synchronous control is not executed.	Please try again after confirming the setting.

Labels

■ Input labels

Name	Variable name	Data type	Setting range	Description
Execution command	i_bEN	Bit	ON, OFF	ON: The FB is activated. OFF: The FB is not activated.
Module label	i_stModule	Structure	The setting range differs depending on the module label.	Specify the module label of the MELSEC iQ-R simple motion module.
Output axis No.	i_uOutputAxis	Word [unsigned]	1 to 16	Set the axis whose current value per cycle after auxiliary shaft gear is to be changed. The setting range differs depending on the module used.
Cd.408: Synchronous control change value	i_dSyncCtrlChange Value	Double word [signed]	-2147483648 to 2147483647	Set the current value per cycle after auxiliary shaft gear to be changed. The setting value is converted within the range from 0 to (Cam axis length per cycle - 1).

■ Output labels

Name	Variable name	Data type	Default value	Description
Execution status	o_bENO	Bit	OFF	ON: The execution command is ON. OFF: The execution command is OFF.
Completed without error	o_bOK	Bit	OFF	When ON, it indicates that changing the current value per cycle after auxiliary shaft gear has been completed.
Error flag	o_bErr	Bit	OFF	When ON, it indicates that an error has occurred in the FB.
Error code	o_uErrId	Word [unsigned]	0	The error code generated in the FB is stored.

Version upgrade history

Version	Date	Description
00D	2014/06/30	First edition

2.27 M+RD77_MoveCamPositionPerCycle

Name

M+RD77_MoveCamPositionPerCycle

Function overview

Item	Description	
Function overview	Adds the movement amount set in the synchronous control change value to a cam axis current value per cycle to move the cam axis current value per cycle.	
Symbol	<div style="text-align: center;"> </div>	
Applicable hardware and software	Applicable module	RD77MS16, RD77MS8, RD77MS4, RD77MS2
	Applicable CPU	MELSEC iQ-R series
	Applicable engineering software	GX Works3
Programming language	Ladder	
Number of steps (maximum)	355 steps	
Function description	<ul style="list-style-type: none"> • By turning ON i_bEN (Execution command), the cam axis current value per cycle of the output axis No. is moved. • If i_bEN (Execution command) is turned OFF during movement of the cam axis current value per cycle, the operation stops during the movement and o_bOK (Completed without error) does not turn ON. • When the setting value of the output axis No. is out of the range, o_bErr (Error flag) turns ON, the FB processing is interrupted, and the error code 100 (Hexadecimal) is stored in o_uErrId (Error code). • When this FB is executed for the output axis No. with which synchronous control is not executed, o_bErr (Error flag) turns ON, the FB processing is interrupted, and the error code 300 (Hexadecimal) is stored in o_uErrId (Error code). 	
Compiling method	Macro type	
FB operation type	Pulsed execution (multiple scan execution type)	

Item	Description
Timing chart	<p>When operation completes without an error</p> <p>When an error occurs</p>
Restrictions and precautions	<ul style="list-style-type: none"> • The FB does not include error recovery processing. Program the error recovery processing separately in accordance with the required system operation. • The FB cannot be used in an interrupt program. • When this FB is used twice or more, precaution must be taken to avoid repetition of the output axis No. • If this FB is used together with other synchronous control change FBs that have the same output axis No., secure one operation cycle or more after o_bOK (Completed without error) of this FB turns ON and before the FBs are executed. • Every input must be provided with a value for proper FB operation.

Error codes

Error code	Description	Action
100 (Hexadecimal)	The output axis No. is not within the setting range.	Please try again after confirming the setting.
300 (Hexadecimal)	The FB is executed for the output axis No. with which synchronous control is not executed.	Please try again after confirming the setting.

Labels

■Input labels

Name	Variable name	Data type	Setting range	Description
Execution command	i_bEN	Bit	ON, OFF	ON: The FB is activated. OFF: The FB is not activated.
Module label	i_stModule	Structure	The setting range differs depending on the module label.	Specify the module label of the MELSEC iQ-R simple motion module.
Output axis No.	i_uOutputAxis	Word [unsigned]	1 to 16	Set the axis number whose cam axis current value per cycle is to be moved. The setting range differs depending on the module used.
Cd.408: Synchronous control change value	i_dSyncCtrlChange Value	Double word [signed]	-2147483648 to 2147483647	Set the amount of the cam axis current value per cycle movement.
Cd.409: Synchronous control reflection time	i_uSyncCtrlReflectionTime	Word [unsigned]	0 to 65535 (ms) (0 to 32767: Set by decimal number. 32768 to 65535: Convert the number to hexadecimal number and set.)	Set the reflection time for the synchronous control change.

■Output labels

Name	Variable name	Data type	Default value	Description
Execution status	o_bENO	Bit	OFF	ON: The execution command is ON. OFF: The execution command is OFF.
Completed without error	o_bOK	Bit	OFF	When ON, it indicates that moving the cam axis current value per cycle has been completed.
Error flag	o_bErr	Bit	OFF	When ON, it indicates that an error has occurred in the FB.
Error code	o_uErrId	Word [unsigned]	0	The error code generated in the FB is stored.

Version upgrade history

Version	Date	Description
00D	2014/06/30	First edition

2.28 M+RD77_MakeRotaryCutterCam

Name

M+RD77_MakeRotaryCutterCam

Function overview

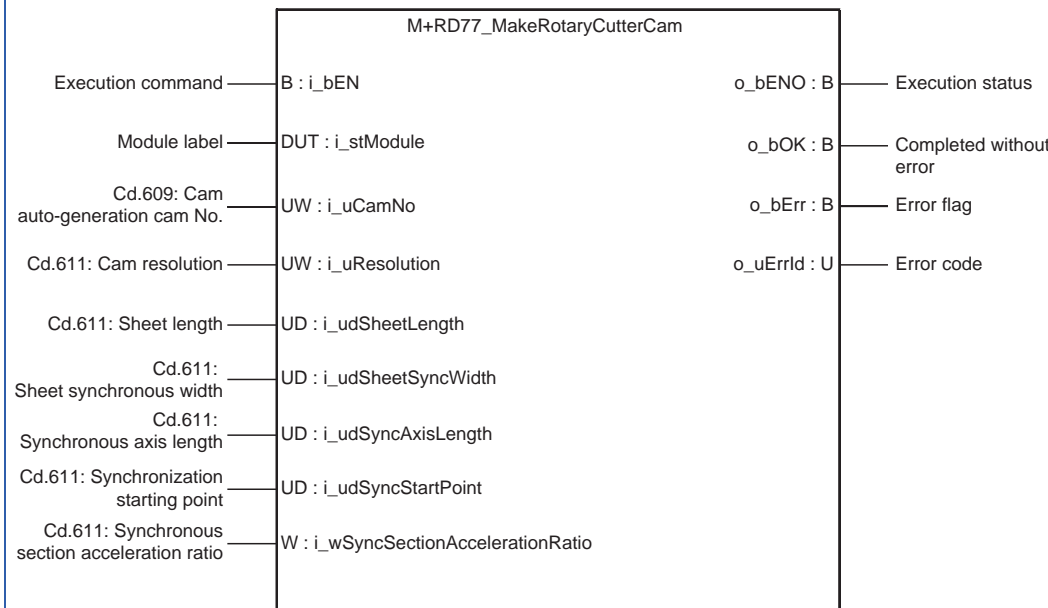
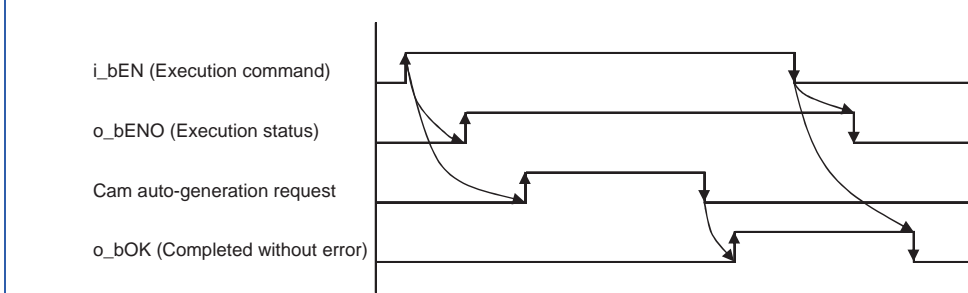
Item	Description						
Function overview	Automatically generates the cam for a rotary cutter.						
Symbol							
Applicable hardware and software	<table border="1"> <tr> <td>Applicable module</td> <td>RD77MS16, RD77MS8, RD77MS4, RD77MS2</td> </tr> <tr> <td>Applicable CPU</td> <td>MELSEC iQ-R series</td> </tr> <tr> <td>Applicable engineering software</td> <td>GX Works3</td> </tr> </table>	Applicable module	RD77MS16, RD77MS8, RD77MS4, RD77MS2	Applicable CPU	MELSEC iQ-R series	Applicable engineering software	GX Works3
Applicable module	RD77MS16, RD77MS8, RD77MS4, RD77MS2						
Applicable CPU	MELSEC iQ-R series						
Applicable engineering software	GX Works3						
Programming language	Ladder						
Number of steps (maximum)	66 steps						
Function description	By turning ON i_bEN (Execution command), the cam for a rotary cutter is automatically generated.						
Compiling method	Macro type						
FB operation type	Pulsed execution (multiple scan execution type)						
Timing chart							
Restrictions and precautions	<ul style="list-style-type: none"> • The FB does not include error recovery processing. Program the error recovery processing separately in accordance with the required system operation. • Even if a warning occurs in the execution of this FB, o_bOK (Completed without error) turns ON. • The FB cannot be used in an interrupt program. • Every input must be provided with a value for proper FB operation. 						

Error codes

Error code	Description	Action
None	None	None

Labels

Input labels

Name	Variable name	Data type	Setting range	Description
Execution command	i_bEN	Bit	ON, OFF	ON: The FB is activated. OFF: The FB is not activated.
Module label	i_stModule	Structure	The setting range differs depending on the module label.	Specify the module label of the MELSEC IQ-R simple motion module.
Cd.609: Cam auto-generation cam No.	i_uCamNo	Word [unsigned]	1 to 256	Set the cam number to be automatically generated.
Cam resolution	i_uResolution	Word [unsigned]	256/512/1024/2048/ 4096/8192/16384/ 32768	Set the resolution of the cam to be generated.
Sheet length	i_udSheetLength	Double word [unsigned]	1 to 2147483647 [(Optional) same unit (such as 0.1 mm)]	Set the sheet length. Set this value in the cam axis length per cycle.
Sheet synchronous width	i_udSheetSyncWidth	Double word [unsigned]	1 to 2147483647 [(Optional) same unit (such as 0.1 mm)]	Set the sheet length of the synchronous section.
Synchronous axis length	i_udSyncAxisLength	Double word [unsigned]	1 to 2147483647 [(Optional) same unit (such as 0.1 mm)]	Set the cycle length of the rotary cutter shaft.
Synchronization starting point	i_udSyncStartPoint	Double word [unsigned]	1 to 2147483647 [(Optional) same unit (such as 0.1 mm)]	Set the length from the beginning of the sheet to the start of the synchronous section.
Synchronous section acceleration ratio	i_wSyncSectionAccelerationRatio	Word [signed]	-5000 to 5000 [0.01%]	Set this label when the synchronous speed in the synchronous section needs to be adjusted. The speed is "Synchronous speed × (100% + Acceleration ratio)" in the synchronous section.

Output labels

Name	Variable name	Data type	Default value	Description
Execution status	o_bENO	Bit	OFF	ON: The execution command is ON. OFF: The execution command is OFF.
Completed without error	o_bOK	Bit	OFF	When ON, it indicates that the cam automatic generation has been completed.
Error flag	o_bErr	Bit	OFF	Always OFF
Error code	o_uErrId	Word [unsigned]	0	Always 0

Version upgrade history

Version	Date	Description
00D	2014/06/30	First edition

2.29 M+RD77_CalcCamCommandPosition

Name

M+RD77_CalcCamCommandPosition

Function overview

Item	Description
Function overview	Calculates a cam axis feed current value, and outputs the calculation result.

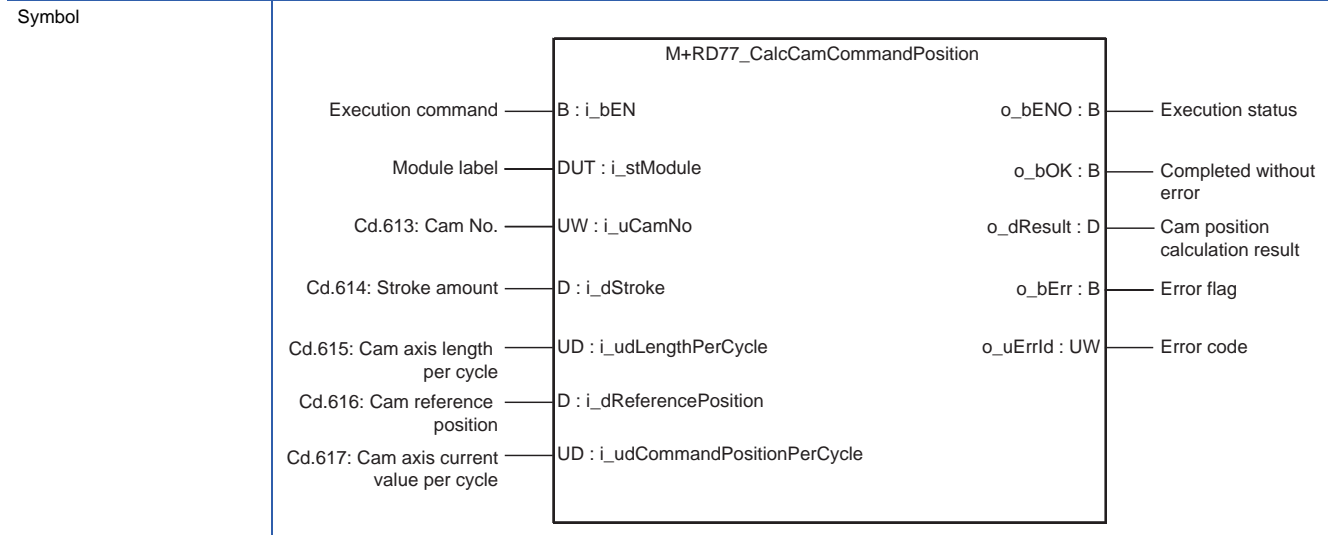

Applicable hardware and software	Applicable module	RD77MS16, RD77MS8, RD77MS4, RD77MS2
	Applicable CPU	MELSEC iQ-R series
	Applicable engineering software	GX Works3

Programming language: Ladder

Number of steps (maximum): 58 steps

Function description: By turning ON i_bEN (Execution command), the cam axis feed current value is calculated.

Compiling method: Macro type

FB operation type: Pulsed execution (multiple scan execution type)

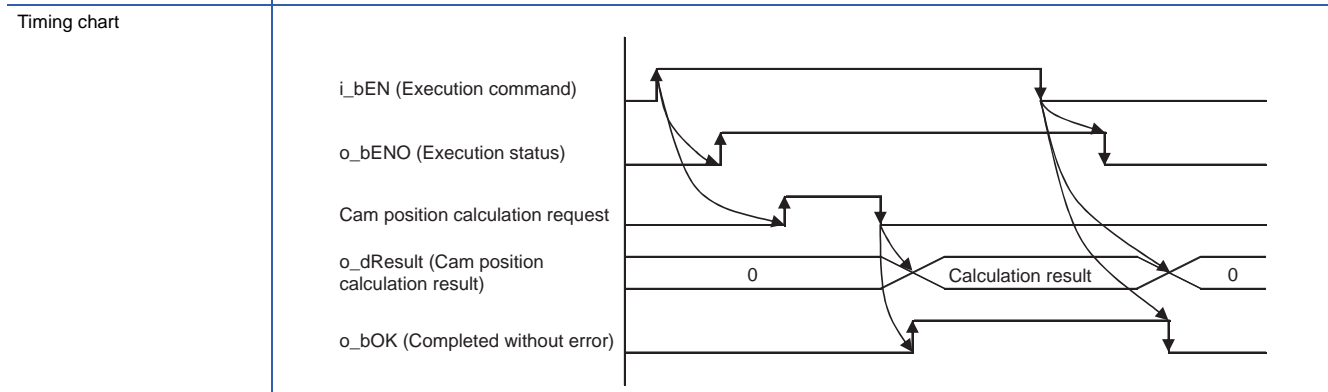

- Restrictions and precautions
- The FB does not include error recovery processing. Program the error recovery processing separately in accordance with the required system operation.
 - Even if a warning occurs in the execution of this FB, o_bOK (Completed without error) turns ON.
 - The FB cannot be used in an interrupt program.
 - Every input must be provided with a value for proper FB operation.

Error codes

Error code	Description	Action
None	None	None

Labels

Input labels

Name	Variable name	Data type	Setting range	Description
Execution command	i_bEN	Bit	ON, OFF	ON: The FB is activated. OFF: The FB is not activated.
Module label	i_stModule	Structure	The setting range differs depending on the module label.	Specify the module label of the MELSEC iQ-R simple motion module.
Cd.613: Cam No.	i_uCamNo	Word [unsigned]	0 to 256	Set the cam number used for the calculation cam.
Cd.614: Stroke amount	i_dStroke	Double word [signed]	-2147483648 to 2147483647	Set the cam stroke amount used for the cam position calculation.
Cd.615: Cam axis length per cycle	i_udLengthPerCycle	Double word [unsigned]	1 to 2147483647	Set the cam axis length per cycle used for the cam position calculation.
Cd.616: Cam reference position	i_dReferencePosition	Double word [signed]	-2147483648 to 2147483647	Set the cam reference position used for the cam position calculation.
Cd.617: Cam axis current value per cycle	i_udCommandPositionPerCycle	Double word [unsigned]	0 to (Cam axis length per cycle)	Set the cam axis current value per cycle used for the cam position calculation.

Output labels

Name	Variable name	Data type	Default value	Description
Execution status	o_bENO	Bit	OFF	ON: The execution command is ON. OFF: The execution command is OFF.
Completed without error	o_bOK	Bit	OFF	When ON, it indicates that calculating the cam axis feed current value has been completed.
Cam position calculation result	o_dResult	Double word [signed]	0	The result of the cam axis feed current value calculation is stored.
Error flag	o_bErr	Bit	OFF	Always OFF
Error code	o_uErrId	Word [unsigned]	0	Always 0

Version upgrade history

Version	Date	Description
00D	2014/06/30	First edition

2.30 M+RD77_CalcCamPositionPerCycle

Name

M+RD77_CalcCamPositionPerCycle

Function overview

Item	Description						
Function overview	Calculates a cam axis current value per cycle, and outputs the calculation result.						
Symbol	<p>The diagram shows a rectangular block labeled 'M+RD77_CalcCamPositionPerCycle'. On the left side, there are seven input lines: 'B : i_bEN' (Execution command), 'DUT : i_stModule' (Module label), 'UW : i_uCamNo' (Cd.613: Cam No.), 'D : i_dStroke' (Cd.614: Stroke amount), 'UD : i_udLengthPerCycle' (Cd.615: Cam axis length per cycle), 'D : i_dReferencePosition' (Cd.616: Cam reference position), and 'UD : i_udCommandPositionPerCycle' (Cd.617: Cam axis current value per cycle). On the right side, there are four output lines: 'B : o_bENO' (Execution status), 'B : o_bOK' (Completed without error), 'D : o_dResult' (Cam position calculation result), and 'UW : o_uErrId' (Error code). There is also an unlabeled output 'B : o_bErr' (Error flag) shown between the 'o_dResult' and 'o_bOK' lines.</p>						
Applicable hardware and software	<table border="1"> <tr> <td>Applicable module</td> <td>RD77MS16, RD77MS8, RD77MS4, RD77MS2</td> </tr> <tr> <td>Applicable CPU</td> <td>MELSEC iQ-R series</td> </tr> <tr> <td>Applicable engineering software</td> <td>GX Works3</td> </tr> </table>	Applicable module	RD77MS16, RD77MS8, RD77MS4, RD77MS2	Applicable CPU	MELSEC iQ-R series	Applicable engineering software	GX Works3
Applicable module	RD77MS16, RD77MS8, RD77MS4, RD77MS2						
Applicable CPU	MELSEC iQ-R series						
Applicable engineering software	GX Works3						
Programming language	Ladder						
Number of steps (maximum)	63 steps						
Function description	By turning ON i_bEN (Execution command), the cam axis current value per cycle is calculated.						
Compiling method	Macro type						
FB operation type	Pulsed execution (multiple scan execution type)						
Timing chart	<p>The timing chart shows five signals over time. 'i_bEN (Execution command)' is a pulse. 'o_bENO (Execution status)' is a pulse that occurs during the execution of the command. 'Cam position calculation request' is a pulse that occurs during the execution. 'o_dResult (Cam position calculation result)' shows a value of 0 before the request, then a 'Calculation result' during the request, and returns to 0 after. 'o_bOK (Completed without error)' is a pulse that occurs after the calculation is complete.</p>						
Restrictions and precautions	<ul style="list-style-type: none"> • The FB does not include error recovery processing. Program the error recovery processing separately in accordance with the required system operation. • Even if a warning occurs in the execution of this FB, o_bOK (Completed without error) turns ON. • The FB cannot be used in an interrupt program. • Every input must be provided with a value for proper FB operation. 						

Error codes

Error code	Description	Action
None	None	None

Labels

Input labels

Name	Variable name	Data type	Setting range	Description
Execution command	i_bEN	Bit	ON, OFF	ON: The FB is activated. OFF: The FB is not activated.
Module label	i_stModule	Structure	The setting range differs depending on the module label.	Specify the module label of the MELSEC iQ-R simple motion module.
Cd.613: Cam No.	i_uCamNo	Word [unsigned]	0 to 256	Set the cam number used for the calculation cam.
Cd.614: Stroke amount	i_dStroke	Double word [signed]	-2147483648 to 2147483647	Set the cam stroke amount used for the cam position calculation.
Cd.615: Cam axis length per cycle	i_udLengthPerCycle	Double word [unsigned]	1 to 2147483647	Set the cam axis length per cycle used for the cam position calculation.
Cd.616: Cam reference position	i_dReferencePosition	Double word [signed]	-2147483648 to 2147483647	Set the cam reference position used for the cam position calculation.
Cd.617: Cam axis current value per cycle	i_udCommandPositionPerCycle	Double word [unsigned]	0 to (Cam axis length per cycle)	Set the current value from which the cam search used for the cam position calculation is started.
Cd.618: Cam axis feed current value	i_dCommandPosition	Double word [signed]	-2147483648 to 2147483647	Set the cam axis feed current value used for the cam position calculation.

Output labels

Name	Variable name	Data type	Default value	Description
Execution status	o_bENO	Bit	OFF	ON: The execution command is ON. OFF: The execution command is OFF.
Completed without error	o_bOK	Bit	OFF	When ON, it indicates that calculating the cam axis current value per cycle has been completed.
Cam position calculation result	o_dResult	Double word [signed]	0	The result of the cam axis current value per cycle calculation is stored.
Error flag	o_bErr	Bit	OFF	Always OFF
Error code	o_uErrId	Word [unsigned]	0	Always 0

Version upgrade history

Version	Date	Description
00D	2014/06/30	First edition

INSTRUCTION INDEX

M

M+RD77_CalcCamCommandPosition	91
M+RD77_CalcCamPositionPerCycle	93
M+RD77_ChangeAccDecTime	23
M+RD77_ChangeAuxiliaryShaftGearPositionPerCycle	83
M+RD77_ChangeCamPositionPerCycle	77
M+RD77_ChangeContinuousTorqueMode	51
M+RD77_ChangeMainShaftGearPositionPerCycle	80
M+RD77_ChangePosition	26
M+RD77_ChangePositionControlMode	48
M+RD77_ChangeServoParameter	39
M+RD77_ChangeSpeed	20
M+RD77_ChangeSpeedControlMode	45
M+RD77_ChangeSyncEncoderPosition	58
M+RD77_ChangeTorqueControlMode	42
M+RD77_ConnectSyncEncoder	71
M+RD77_DisableSyncEncoder	61
M+RD77_EnableSyncEncoder	64
M+RD77_InitializeParameter	35
M+RD77_JOG	14
M+RD77_MakeRotaryCutterCam	89
M+RD77_MoveCamPositionPerCycle	86
M+RD77_MoveCamReferencePosition	74
M+RD77_MPG	17
M+RD77_OperateError	32
M+RD77_ResetSyncEncoderError	67
M+RD77_Restart	29
M+RD77_SetPositioningData	4
M+RD77_StartPositioning	11
M+RD77_Sync	55
M+RD77_WriteFlash	37



MEMO

REVISIONS

*The manual number is given on the bottom left of the back cover.

Revision date	*Manual number	Description
June 2014	BCN-B62005-691ENG-A	First edition
August 2014	BCN-B62005-691ENG-B	Partial correction
May 2018	BCN-B62005-691ENG-C	Partial correction

Japanese manual number: BCN-B62005-690-C

This manual confers no industrial property rights of any other kind, nor does it confer any patent licenses. Mitsubishi Electric Corporation cannot be held responsible for any problems involving industrial property rights which may occur as a result of using the contents noted in this manual.

© 2014 MITSUBISHI ELECTRIC CORPORATION

BCN-B62005-691ENG-C(1805)MEE

mitsubishi electric corporation

HEAD OFFICE : TOKYO BUILDING, 2-7-3 MARUNOUCHI, CHIYODA-KU, TOKYO 100-8310, JAPAN
NAGOYA WORKS : 1-14, YADA-MINAMI 5-CHOME, HIGASHI-KU, NAGOYA, JAPAN

When exported from Japan, this manual does not require application to the
Ministry of Economy, Trade and Industry for service transaction permission.

Specifications subject to change without notice.